

Features

- Operating Voltage: 12V~72V
- 2A Constant Output Current Capability
- Max. IO_{UT}=1.2A at V_{OUT}=5V
- Max. IO_{UT}=0.8A at V_{OUT}=12V
- High Light-Load Efficiency
- High efficiency up to 93%
- Built in power MOSFET
- Feedback Voltage Accuracy ± 2%
- Excellent line and load regulation
- Built in thermal shutdown function
- Built in current limit protection function
- Temperature Grade 1: -40°C to 125°C Ambient Operating Temperature Range
- Device HBM ESD Classification Level Class3A
- Available in SOP8 package

General Description

The XL7055 is a 140 kHz fixed frequency buck DC/DC converter, capable of driving a 2A load with high voltage, high efficiency. A built-in loop compensation module reduces components in the system, lowering power system cost and reducing printed circuit board space. The XL7055 has built-in thermal shutdown, current limit protection and so on.

Applications

- POE Switch
- Automotive Electronics
- Industrial Control
- Networking Equipment
- Internet of Things

Typical application schematic

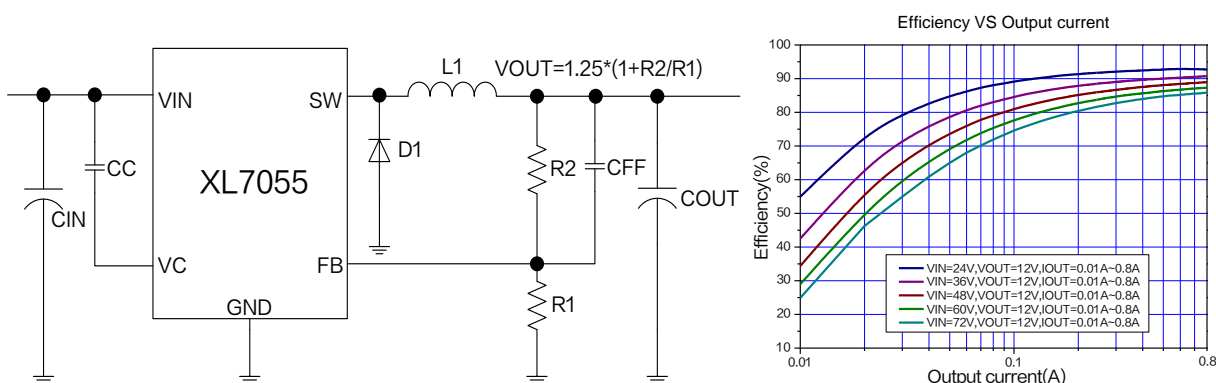

Figure1.XL7055 Typical application schematic and efficiency curve

Pin Configurations

| | | | |
|-----|---|---|-----|
| GND | 1 | 8 | GND |
| FB | 2 | 7 | GND |
| VC | 3 | 6 | SW |
| VIN | 4 | 5 | SW |

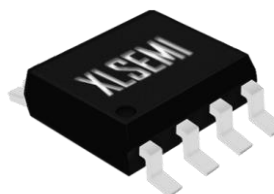

Figure2.Pin Configuration of XL7055

Table 1.Pin Description

| Pin Number | Pin Name | Description |
|------------|----------|--|
| 1,7,8 | GND | Ground Pin. |
| 2 | FB | Feedback Pin (FB). Through an external resistor divider network, detects the output voltage for adjustment, with an adjustable version reference voltage of 1.25V. |
| 3 | VC | Internal Voltage Regulator Bypass Capacity. In typical system application, The VC pin connect a 0.1 μ F capacitor to VIN |
| 4 | VIN | Supply Voltage Input Pin. XL7055 DC operating voltage range from a 12V to 72V. Bypass VIN to GND with a suitably large capacitor to eliminate noise on the input. |
| 5-6 | SW | Power Switch Output Pin (SW). |

Ordering Information

| Order Information | Marking ID | Package Type | Eco Plan | Packing Type Supplied As |
|-------------------|------------|--------------|-----------|--------------------------|
| XL7055 | XL7055 | SOP8 | RoHS & HF | 4000 Units on Reel |

Function Block

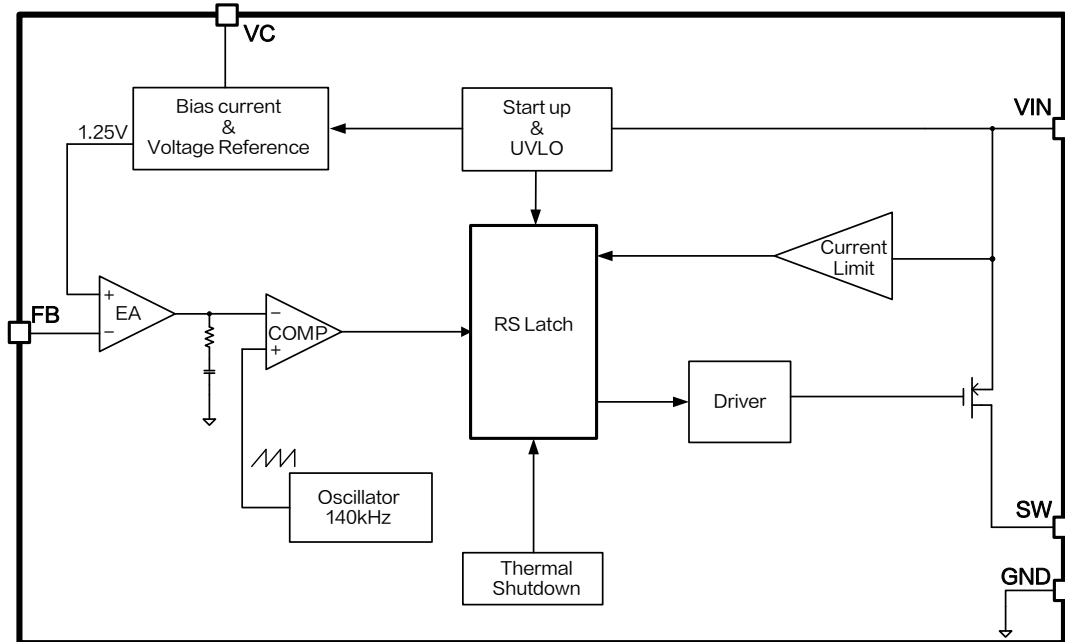

Figure3.Function Block Diagram of XL7055

Absolute Maximum Ratings (Note1)

| Parameter | Symbol | Value | Unit |
|---|------------|-----------------------|------|
| Input Voltage | V_{IN} | -0.3~80 | V |
| Feedback Pin Voltage | V_{FB} | -0.3~7 | V |
| VC Pin Voltage | V_C | $V_{IN}-7\sim V_{IN}$ | V |
| Output Switch Pin Voltage | V_{SW} | -0.3~ V_{IN} | V |
| Power Dissipation | P_D | Internally limited | mW |
| Thermal Resistance (SOP8) (Junction to Ambient, No Heatsink, Free Air) | R_{JA} | 100 | °C/W |
| Operating Junction Temperature | T_J | -40~150 | °C |
| Storage Temperature | T_{STG} | -65~150 | °C |
| Lead Temperature (Soldering, 10 sec) | T_{LEAD} | 260 | °C |
| ESD (HBM) | - | ≥4000 | V |

Note1: Stresses greater than those listed under Maximum Ratings may cause permanent damage to the device. This is a stress rating only and functional operation of the device at these or any other conditions above those indicated in the operation is not implied. Exposure to absolute maximum rating conditions for extended periods may affect reliability.

140kHz 80V 2A Buck DC to DC Converter

XL7055

XL7055 Electrical Characteristics

$T_A = 25^\circ\text{C}$; System parameters test circuit figure4 and figure6, unless otherwise specified.

| Symbol | Parameter | Test Condition | Min. | Typ. | Max. | Unit |
|----------|------------------|---|-------|------|-------|------|
| V_{FB} | Feedback Voltage | $V_{IN}=18V-72V, V_{OUT}=12V$ $I_{OUT}=0.5A$ | 1.225 | 1.25 | 1.275 | V |
| η | Efficiency | $V_{IN}=24V, V_{OUT}=5.0V$ $I_{OUT}=1.2A$ | - | 82.3 | - | % |
| η | Efficiency | $V_{IN}=24V, V_{OUT}=12V$ $I_{OUT}=0.8A$ | - | 92.7 | - | % |
| η | Efficiency | $V_{IN}=36V, V_{OUT}=5.0V$ $I_{OUT}=1.2A$ | - | 81.2 | - | % |
| η | Efficiency | $V_{IN}=36V, V_{OUT}=12V$ $I_{OUT}=0.8A$ | - | 90.4 | - | % |
| η | Efficiency | $V_{IN}=48V, V_{OUT}=5.0V$ $I_{OUT}=1.2A$ | - | 80.2 | - | % |
| η | Efficiency | $V_{IN}=48V, V_{OUT}=12V$ $I_{OUT}=0.8A$ | - | 88.5 | - | % |

Electrical Characteristics (DC Parameters)

$T_A = 25^\circ\text{C}$, $V_{IN} = 48V$, System parameters test circuit figure6, unless otherwise specified.

| Parameters | Symbol | Test Condition | Min. | Typ. | Max. | Unit |
|------------------------------|--------------|-------------------------------|------|------|------|------------------|
| Operating Voltage | V_{IN} | - | 20 | - | 72 | V |
| Quiescent Current | I_Q | $V_{FB}=2V$ | - | 1.7 | 2.5 | mA |
| Oscillator Frequency | F_{OSC} | - | 110 | 140 | 170 | kHz |
| Switch Current Limit | I_L | - | - | 3.0 | - | A |
| MOS On-resistance | $R_{DS(ON)}$ | $V_{IN}=48V$ $I_{SW}=0.8A$ | - | 300 | - | m Ω |
| Max. Duty Cycle | D_{MAX} | $V_{FB}=0V$ | - | 90 | - | % |
| Thermal Shutdown Temperature | T_{SD} | - | - | 150 | - | $^\circ\text{C}$ |

Typical System Application Schematic ($V_{OUT}=5V, I_{OUT}=0\sim 1.2A$)

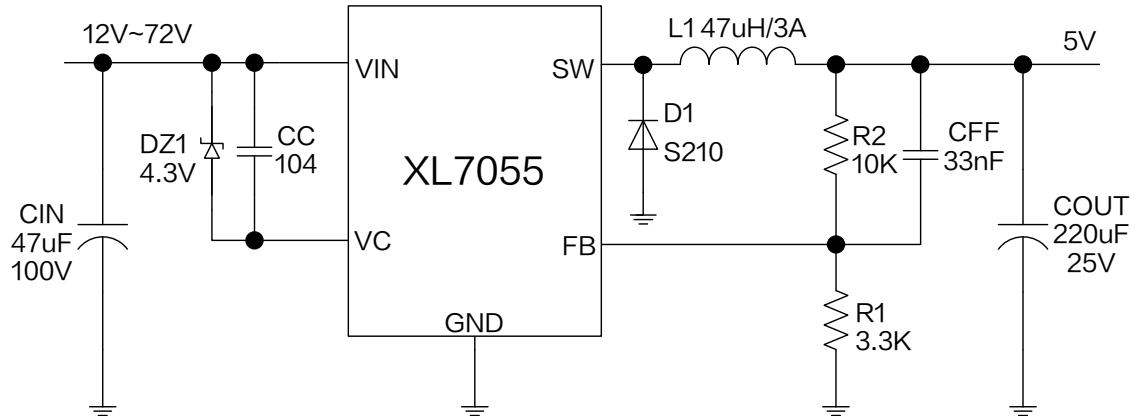

Figure4. XL7055 System Parameters Test Circuit ($V_{IN}=12V\sim 72V, V_{OUT}=5V, I_{OUT}=0\sim 1.2A$)

Typical System Application Transfer Efficiency

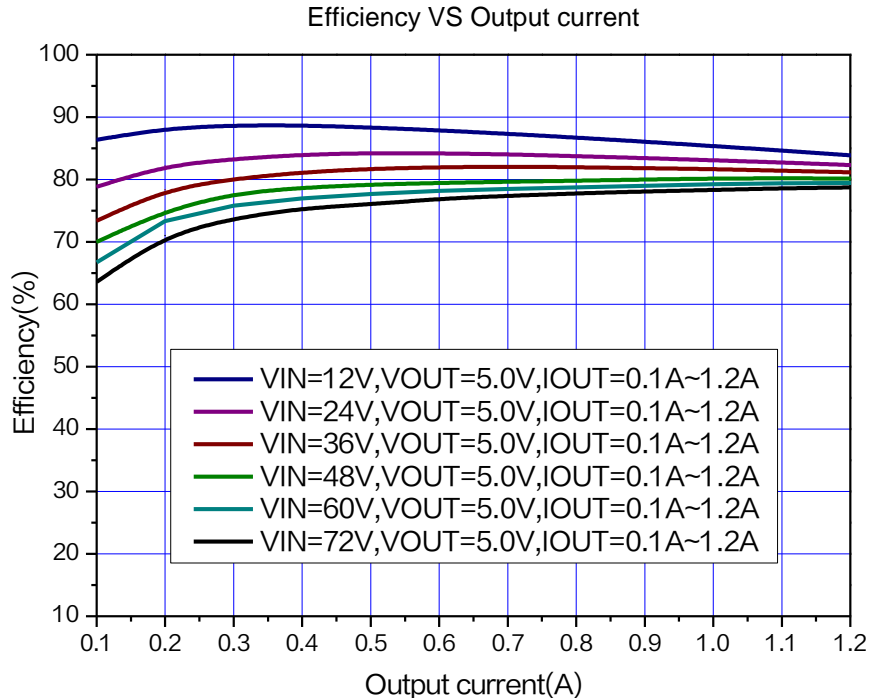

Figure5. XL7055 System Efficiency Curve ($V_{OUT}=5.0V$)

Typical System Application Schematic ($V_{OUT}=12V, I_{OUT}=0\sim 0.8A$)

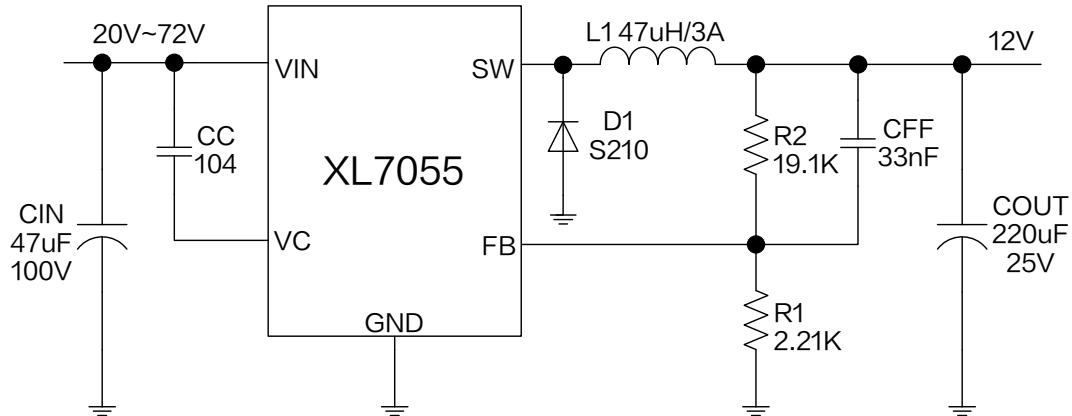

Figure6.XL7055 System Parameters Test Circuit ($V_{IN}=20V\sim 72V, V_{OUT}=12V, I_{OUT}=0\sim 0.8A$)

Typical System Application Transfer Efficiency

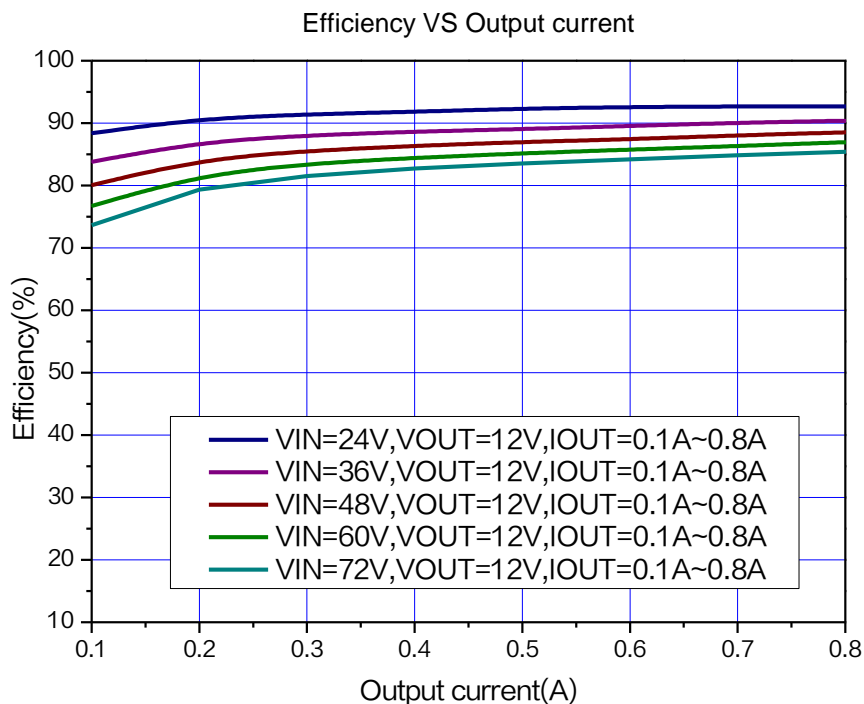

Figure7.XL7055 System Efficiency Curve ($V_{OUT}=12V$)

Typical Characteristics

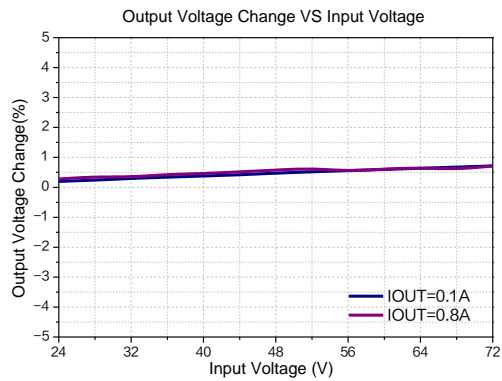

Figure8.Line Regulation

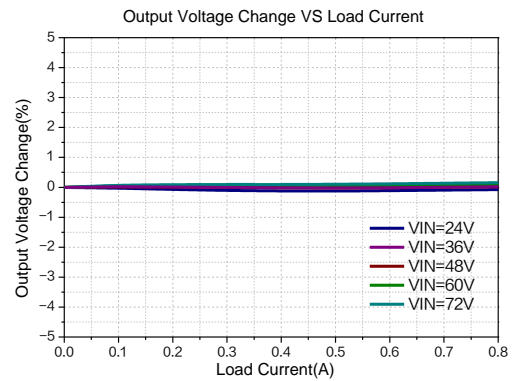

Figure9.Load Regulation

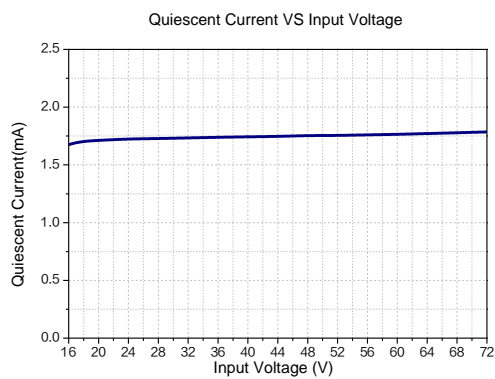

Figure10.Quiescent Current

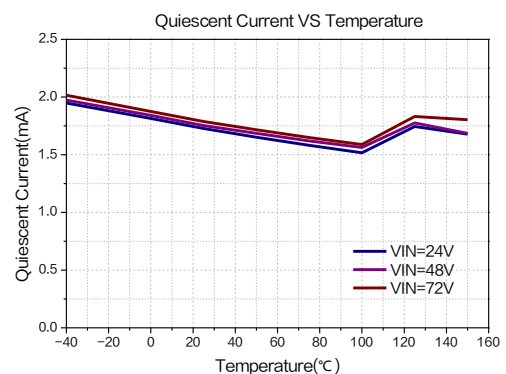

Figure11.Quiescent Current

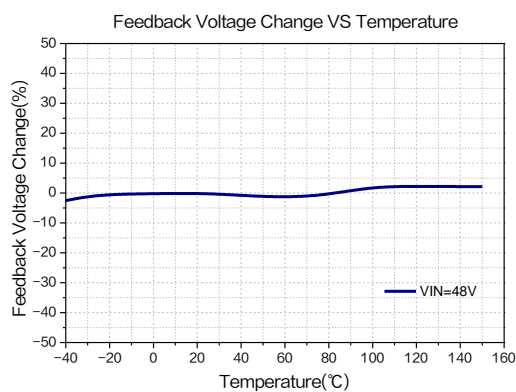

Figure12.Feedback Voltage Regulation

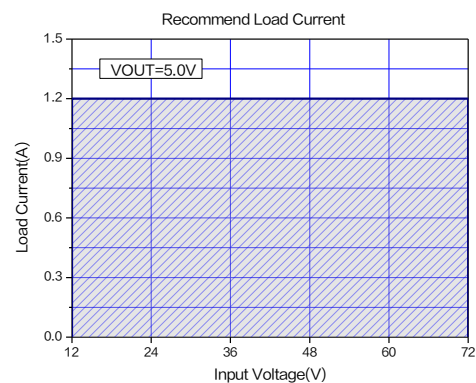

Figure 13.Max Output Current
($V_{OUT}=5.0V, T_A=25^\circ C$)

140kHz 80V 2A Buck DC to DC Converter

XL7055

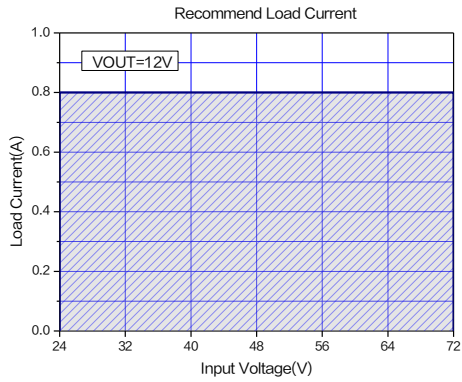

Figure 14. Max Output Current
($V_{OUT}=12V$, $T_A=25^{\circ}C$)

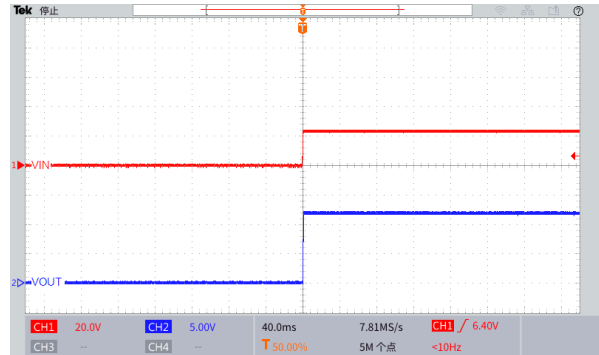

Figure 15. Start-Up Characteristic
($V_{IN}=24V$, $V_{OUT}=12V$, $I_{OUT}=0.1A$)

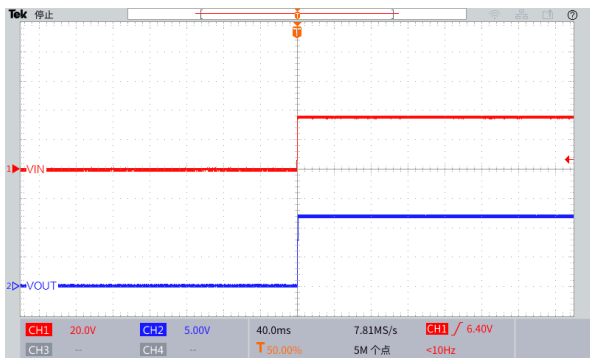

Figure 16. Start-Up Characteristic
($V_{IN}=36V$, $V_{OUT}=12V$, $I_{OUT}=0.1A$)

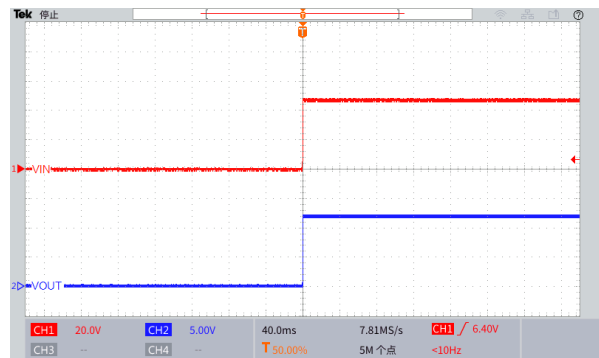

Figure 17. Start-Up Characteristic
($V_{IN}=48V$, $V_{OUT}=12V$, $I_{OUT}=0.1A$)



Figure 18. Start-Up Characteristic
($V_{IN}=60V$, $V_{OUT}=12V$, $I_{OUT}=0.1A$)

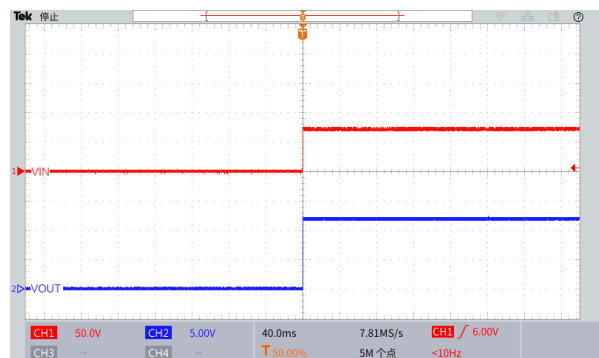

Figure 19. Start-Up Characteristic
($V_{IN}=72V$, $V_{OUT}=12V$, $I_{OUT}=0.1A$)

140kHz 80V 2A Buck DC to DC Converter

XL7055

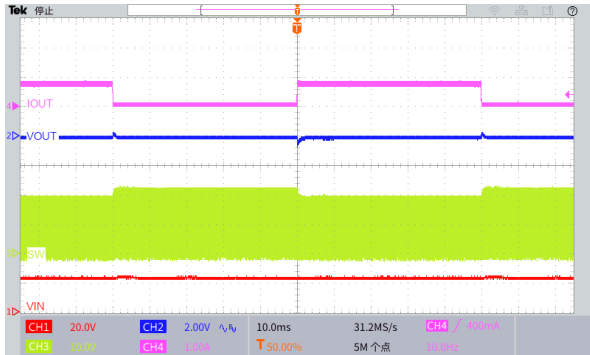

Figure 20. Load Transient Response
($V_{IN}=24V$, $V_{OUT}=12V$, $I_{OUT}=0.1$ to $0.8A$)

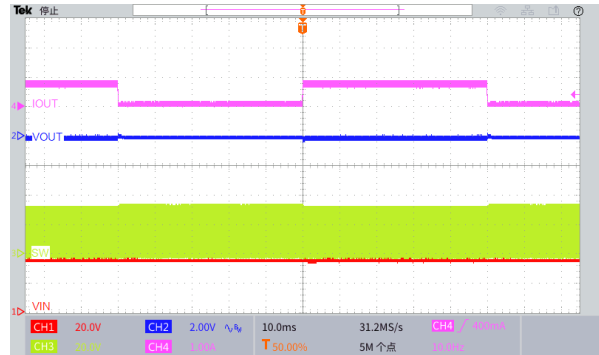

Figure 21. Load Transient Response
($V_{IN}=36V$, $V_{OUT}=12V$, $I_{OUT}=0.1$ to $0.8A$)

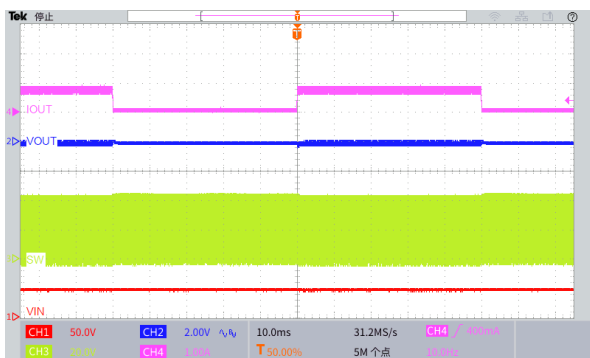

Figure 22. Load Transient Response
($V_{IN}=48V$, $V_{OUT}=12V$, $I_{OUT}=0.1$ to $0.8A$)

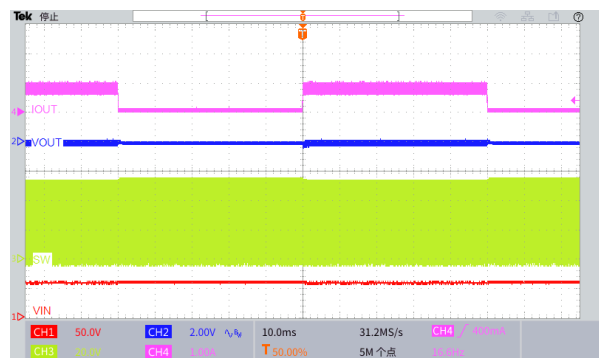

Figure 23. Load Transient Response
($V_{IN}=60V$, $V_{OUT}=12V$, $I_{OUT}=0.1$ to $0.8A$)

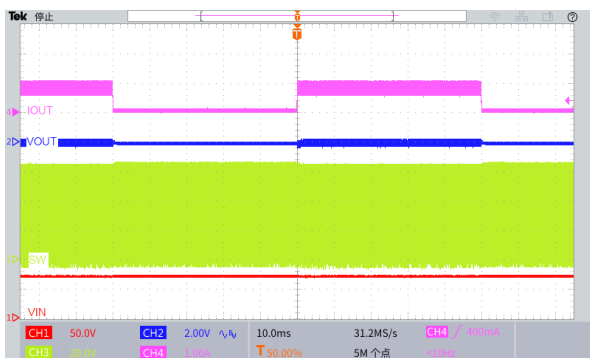
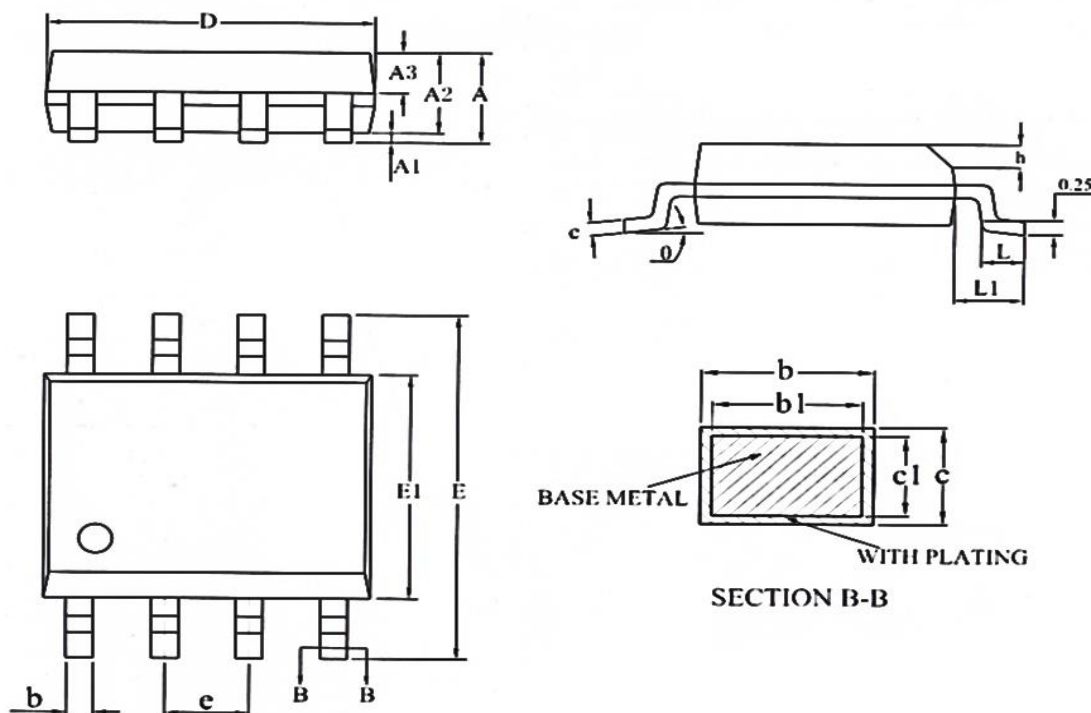

Figure 24. Load Transient Response
($V_{IN}=72V$, $V_{OUT}=12V$, $I_{OUT}=0.1$ to $0.8A$)

Package Information

SOP8



| Symbol | Dimensions In Millimeters | | | Dimensions In Inches | | |
|--------|---------------------------|------|------|----------------------|-------|-------|
| | Min. | Nom. | Max. | Min. | Nom. | Max. |
| A | 1.35 | 1.55 | 1.75 | 0.053 | 0.061 | 0.069 |
| A1 | 0.05 | - | 0.25 | 0.002 | - | 0.010 |
| A2 | 1.25 | 1.40 | 1.65 | 0.049 | 0.055 | 0.065 |
| A3 | 0.50 | 0.60 | 0.70 | 0.019 | 0.024 | 0.028 |
| b | 0.30 | - | 0.51 | 0.012 | - | 0.020 |
| b1 | 0.29 | 0.41 | 0.48 | 0.011 | 0.016 | 0.018 |
| c | 0.17 | - | 0.25 | 0.007 | - | 0.010 |
| c1 | 0.17 | 0.20 | 0.23 | 0.007 | 0.008 | 0.009 |
| D | 4.70 | 4.90 | 5.10 | 0.185 | 0.193 | 0.200 |
| E | 5.80 | 6.00 | 6.20 | 0.228 | 0.236 | 0.244 |
| E1 | 3.80 | 3.90 | 4.00 | 0.150 | 0.154 | 0.157 |
| e | 1.14 | 1.27 | 1.40 | 0.045 | 0.050 | 0.055 |
| h | 0.25 | - | 0.50 | 0.010 | - | 0.020 |
| L | 0.45 | - | 0.80 | 0.017 | - | 0.031 |
| L1 | 0.82 | 1.03 | 1.23 | 0.032 | 0.040 | 0.048 |
| θ | 0 | - | 8° | 0 | - | 8° |

| | |
|---------------------------------------|--------|
| 140kHz 80V 2A Buck DC to DC Converter | XL7055 |
|---------------------------------------|--------|

Important Notice

XLSEMI reserve the right to make modifications, enhancements, improvements, corrections or other changes without notice at any time. XLSEMI does not assume any liability arising out of the application or use of any product described herein; neither does it convey any license under its patent rights, nor the rights of others. XLSEMI assumes no liability for applications assistance or the design of Buyers' products. Buyers are responsible for their products and applications using XLSEMI components. To minimize the risks associated with Buyers' products and applications, Buyers should provide adequate design and operating safeguards. XLSEMI warrants performance of its products to the specifications applicable at the time of sale, in accordance with the warranty in XLSEMI's terms and conditions of sale of semiconductor products. Testing and other quality control techniques are used to the extent XLSEMI deems necessary to support this warranty. Except where mandated by applicable law, testing of all parameters of each component is not necessarily performed.

For the latest product information, go to www.xlsemi.com.