

Features

- Operating Voltage: 12V~72V
- 2A Constant Output Current Capability
- Max. IOUT=1.6A at VOUT=5V
- Max. IOUT=1.2A at VOUT=12V
- High Light-Load Efficiency
- High efficiency up to 93%
- Built in power MOSFET
- Eliminates the need for an external freewheeling Schottky diode
- Feedback Voltage Accuracy $\pm 2\%$
- Excellent line and load regulation
- Built in thermal shutdown function
- Built in current limit protection function
- Temperature Grade 1: -40°C to 125°C Ambient Operating Temperature Range
- Device HBM ESD Classification Level Class3A
- Available in TO252-5L package

General Description

The XL7058 is a 140 kHz fixed frequency buck DC/DC converter, capable of driving a 2A load with high voltage, high efficiency. A built-in loop compensation module reduces components in the system, lowering power system cost and reducing printed circuit board space. The XL7058 has built-in thermal shutdown, current limit protection and so on.

Applications

- POE Switch
- Automotive Electronics
- Industrial Control
- Networking Equipment
- Internet of Things

Typical application schematic

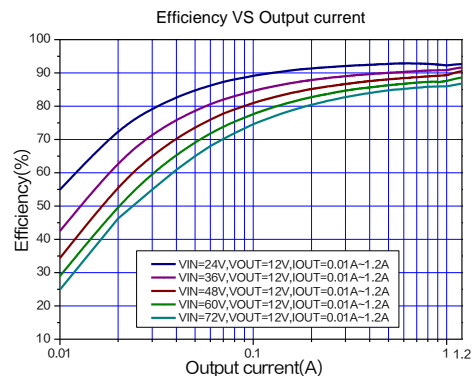
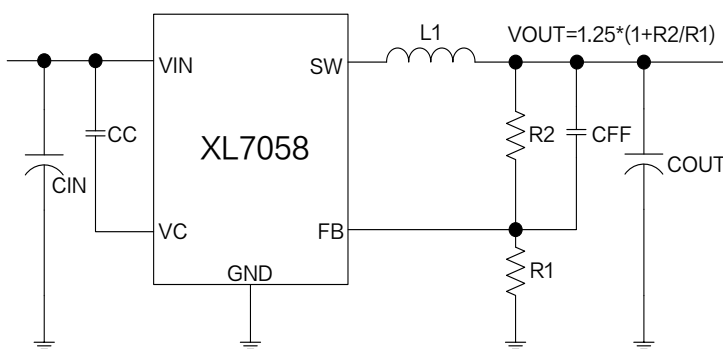

Figure1.XL7058 Typical application schematic and efficiency curve

Pin Configurations

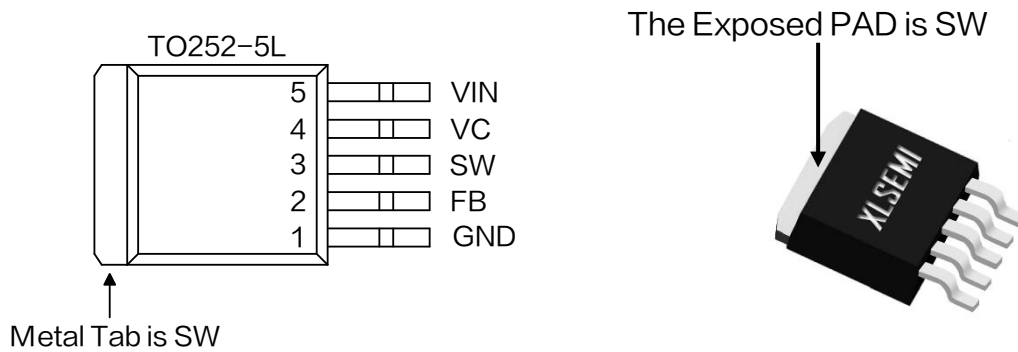

Figure2.Pin Configuration of XL7058

Table 1.Pin Description

Pin Number	Pin Name	Description
1	GND	Ground Pin.
2	FB	Feedback Pin (FB). Through an external resistor divider network, detects the output voltage for adjustment, with an adjustable version reference voltage of 1.25V.
3	SW	Power Switch Output Pin (SW).
4	VC	Internal Voltage Regulator Bypass Capacity. In typical system application, The VC pin connect a 0.1 μ F capacitor to VIN
5	VIN	Supply Voltage Input Pin. XL7058 DC operating voltage range from a 12V to 72V. Bypass VIN to GND with a suitably large capacitor to eliminate noise on the input.

Ordering Information

Order Information	Marking ID	Package Type	Eco Plan	Packing Type Supplied As
XL7058	XL7058	TO252-5L	RoHS & HF	2500 Units on Reel

Function Block

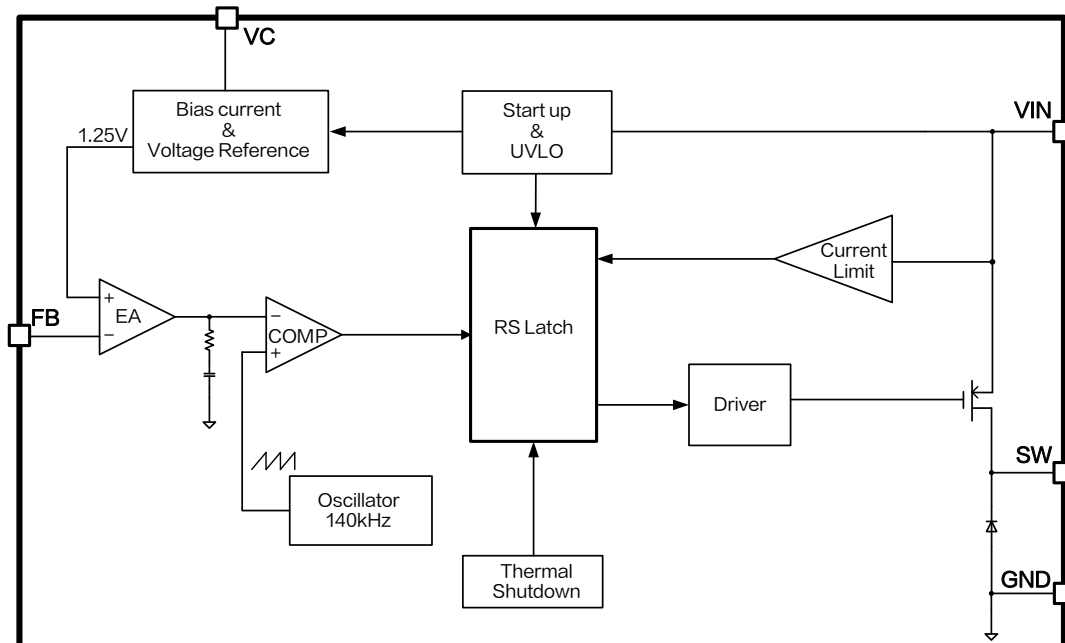

Figure3.Function Block Diagram of XL7058

Absolute Maximum Ratings (Note1)

Parameter	Symbol	Value	Unit
Input Voltage	V_{IN}	-0.3~80	V
Feedback Pin Voltage	V_{FB}	-0.3~7	V
VC Pin Voltage	V_C	$V_{IN}-7 \sim V_{IN}$	V
Output Switch Pin Voltage	V_{SW}	-0.3~ V_{IN}	V
Power Dissipation	P_D	Internally limited	mW
Thermal Resistance (TO252-5L) (Junction to Ambient, No Heatsink, Free Air)	R_{JA}	50	°C/W
Operating Junction Temperature	T_J	-40~150	°C
Storage Temperature	T_{STG}	-65~150	°C
Lead Temperature (Soldering, 10 sec)	T_{LEAD}	260	°C
ESD (HBM)	-	≥4000	V

Note1: Stresses greater than those listed under Maximum Ratings may cause permanent damage to the device. This is a stress rating only and functional operation of the device at these or any other conditions above those indicated in the operation is not implied. Exposure to absolute maximum rating conditions for extended periods may affect reliability.

140kHz 80V 2A Buck DC to DC Converter

XL7058

XL7058 Electrical Characteristics

T_A = 25°C; System parameters test circuit figure4 and figure6, unless otherwise specified.

Symbol	Parameter	Test Condition	Min.	Typ.	Max.	Unit
V _{FB}	Feedback Voltage	V _{IN} =18V-72V, V _{OUT} =12V I _{OUT} =0.5A	1.225	1.25	1.275	V
η	Efficiency	V _{IN} =24V, V _{OUT} =5.0V I _{OUT} =1.6A	-	84.8	-	%
η	Efficiency	V _{IN} =24V, V _{OUT} =12V I _{OUT} =1.2A	-	92.8	-	%
η	Efficiency	V _{IN} =36V, V _{OUT} =5.0V I _{OUT} =1.6A	-	83.5	-	%
η	Efficiency	V _{IN} =36V, V _{OUT} =12V I _{OUT} =1.2A	-	91.8	-	%
η	Efficiency	V _{IN} =48V, V _{OUT} =5.0V I _{OUT} =1.6A	-	84.0	-	%
η	Efficiency	V _{IN} =48V, V _{OUT} =12V I _{OUT} =1.2A	-	90.8	-	%

Electrical Characteristics (DC Parameters)

T_A = 25°C, V_{IN} = 48V, System parameters test circuit figure6, unless otherwise specified.

Parameters	Symbol	Test Condition	Min.	Typ.	Max.	Unit
Operating Voltage	V _{IN}	-	20	-	72	V
Quiescent Current	I _Q	V _{FB} =2V	-	1.7	2.5	mA
Oscillator Frequency	F _{OSC}	-	110	140	170	kHz
Switch Current Limit	I _L	-	-	3.5	-	A
MOS On-resistance	R _{DS(ON)}	V _{IN} =48V I _{SW} =1.0A	-	300	-	mΩ
Max. Duty Cycle	D _{MAX}	V _{FB} =0V	-	90	-	%
Thermal Shutdown Temperature	T _{SD}	-	-	150	-	°C

Typical System Application Schematic ($V_{OUT}=5V, I_{OUT}=0\sim 1.6A$)

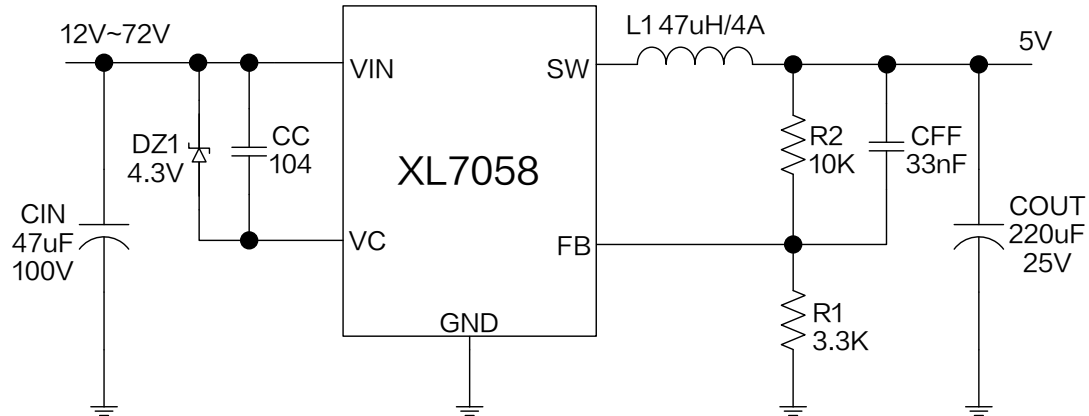

Figure4. XL7058 System Parameters Test Circuit ($V_{IN}=12V\sim 72V, V_{OUT}=5V, I_{OUT}=0\sim 1.6A$)

Typical System Application Transfer Efficiency

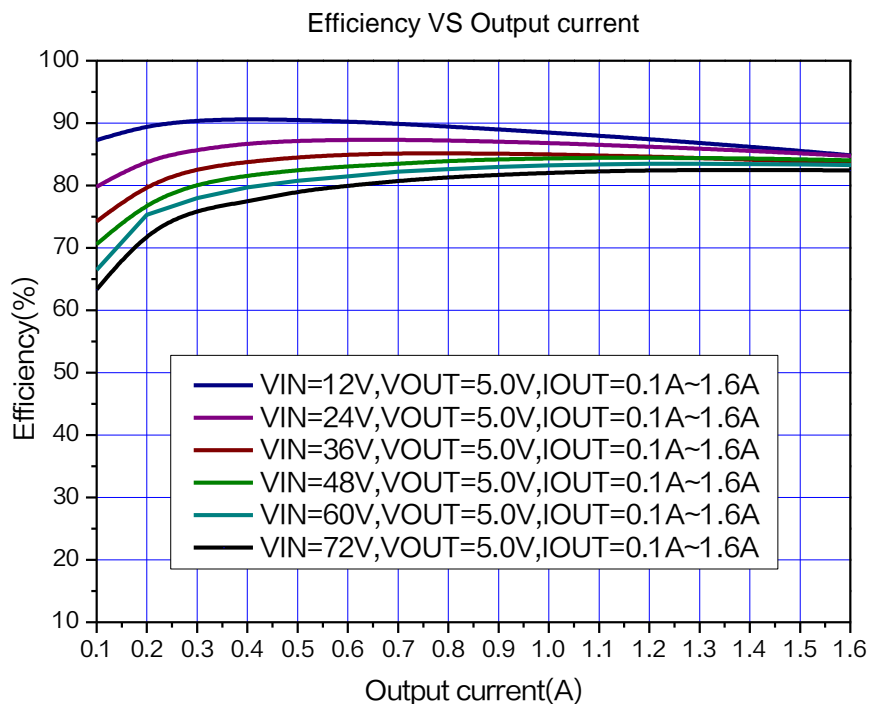

Figure5. XL7058 System Efficiency Curve ($V_{OUT}=5.0V$)

Typical System Application Schematic ($V_{OUT}=12V$, $I_{OUT}=0\sim 1.2A$)

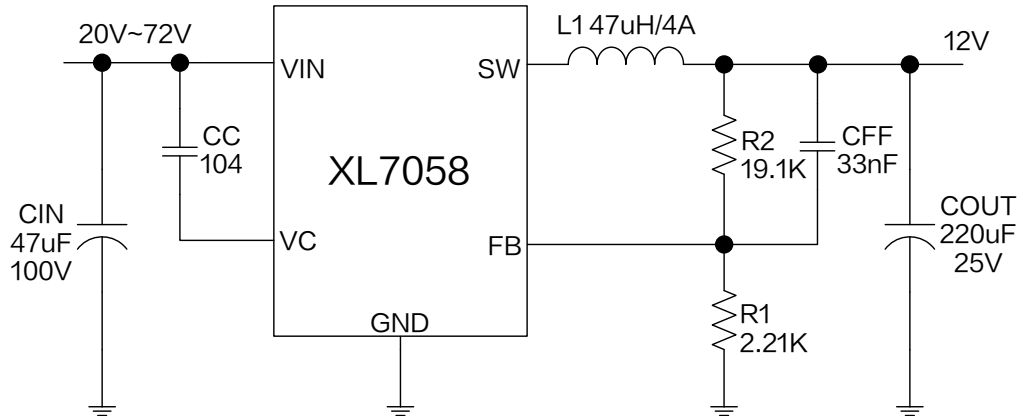

Figure6.XL7058 System Parameters Test Circuit ($V_{IN}=20V\sim 72V$, $V_{OUT}=12V$, $I_{OUT}=0\sim 1.2A$)

Typical System Application Transfer Efficiency

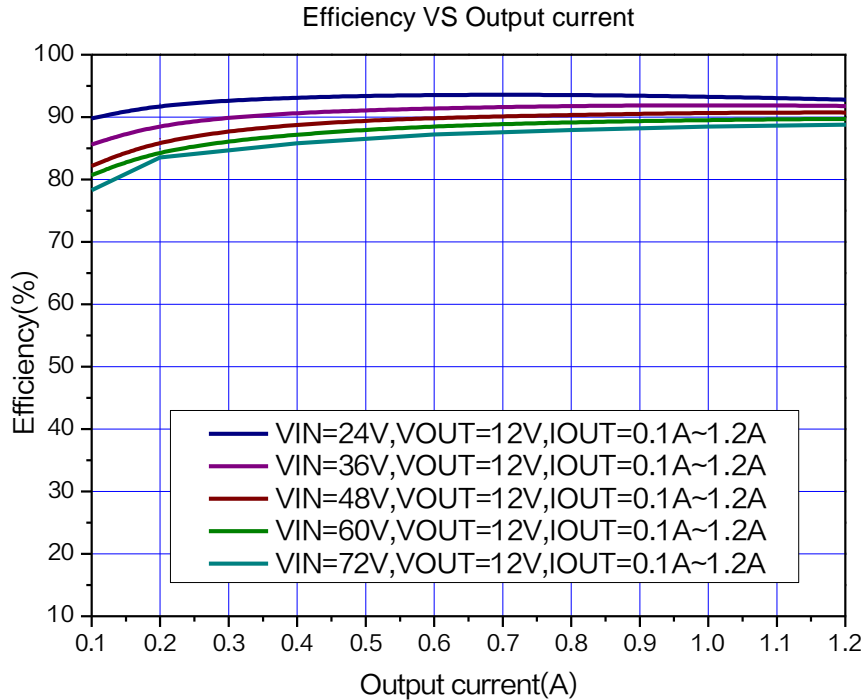
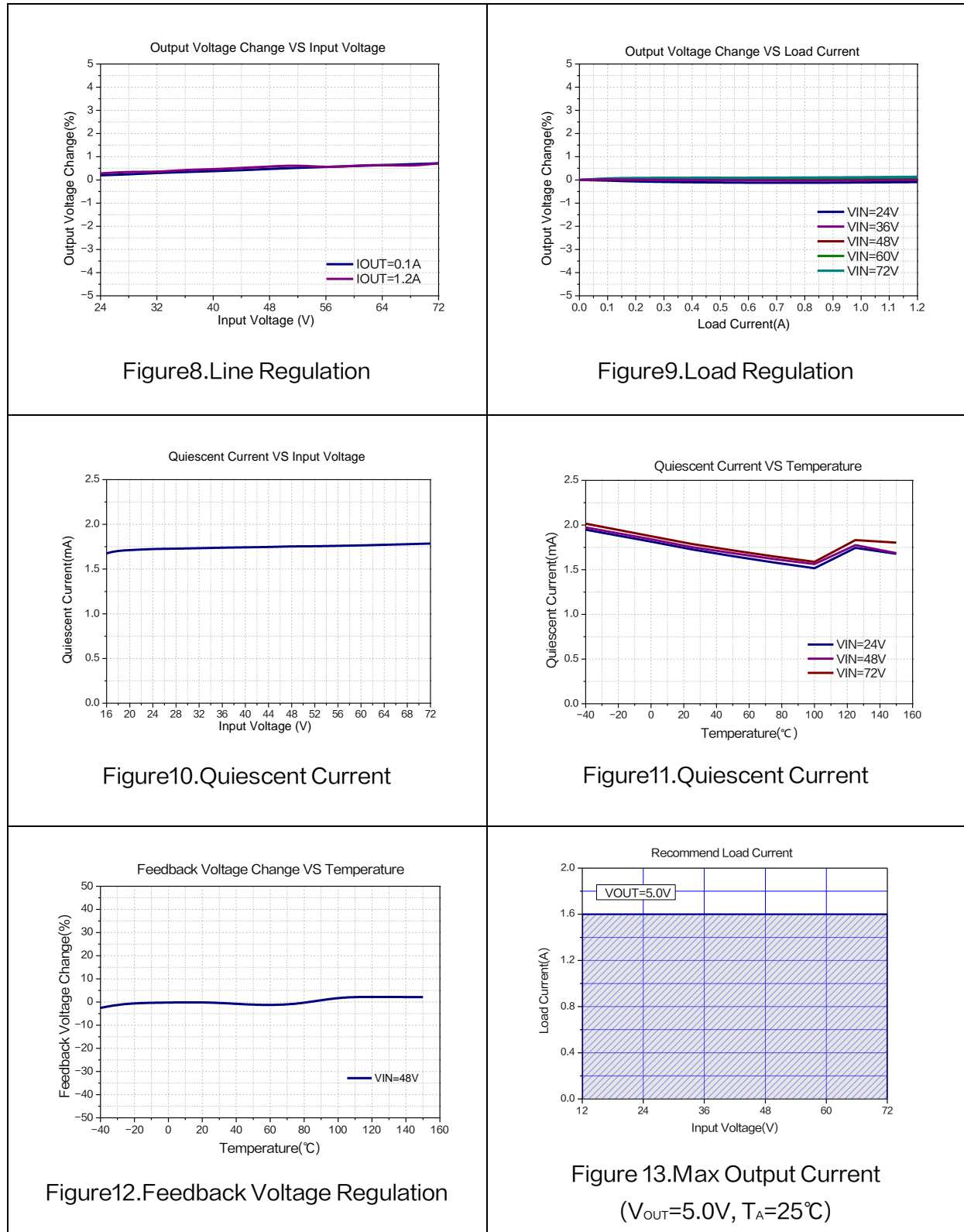

Figure7.XL7058 System Efficiency Curve ($V_{OUT}=12V$)

Typical Characteristics



140kHz 80V 2A Buck DC to DC Converter

XL7058

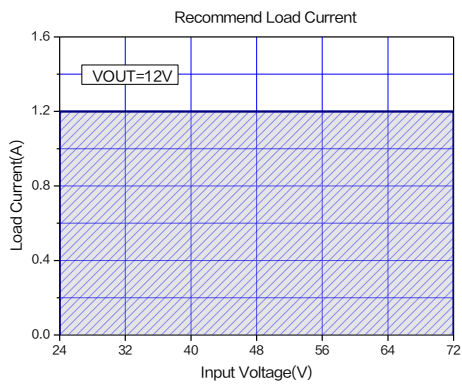

Figure 14. Max Output Current
($V_{OUT}=12V$, $T_A=25^{\circ}C$)

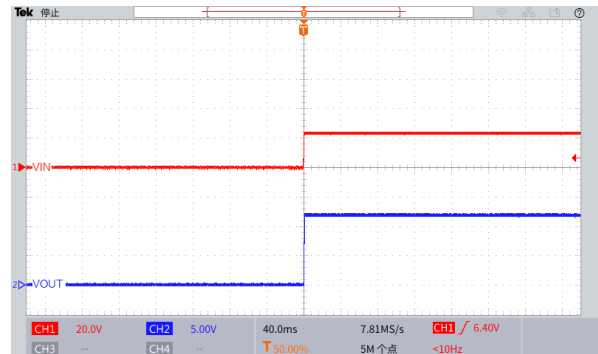

Figure 15. Start-Up Characteristic
($V_{IN}=24V$, $V_{OUT}=12V$, $I_{OUT}=0.1A$)

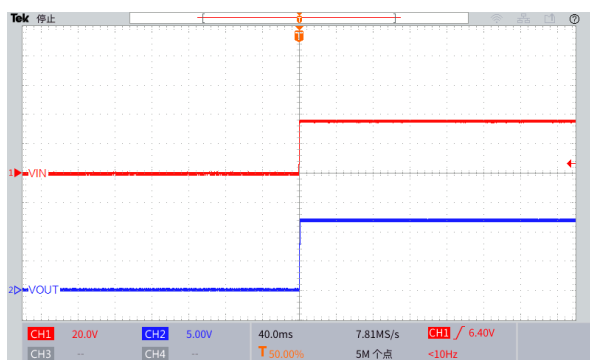

Figure 16. Start-Up Characteristic
($V_{IN}=36V$, $V_{OUT}=12V$, $I_{OUT}=0.1A$)

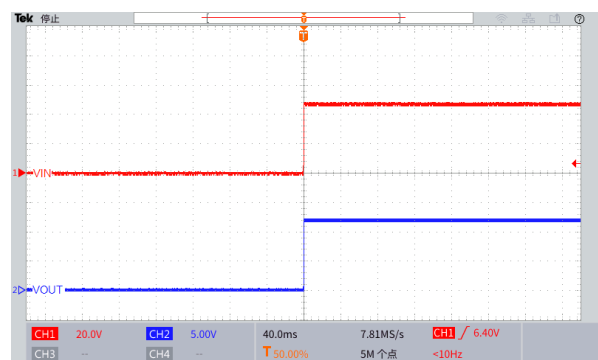

Figure 17. Start-Up Characteristic
($V_{IN}=48V$, $V_{OUT}=12V$, $I_{OUT}=0.1A$)

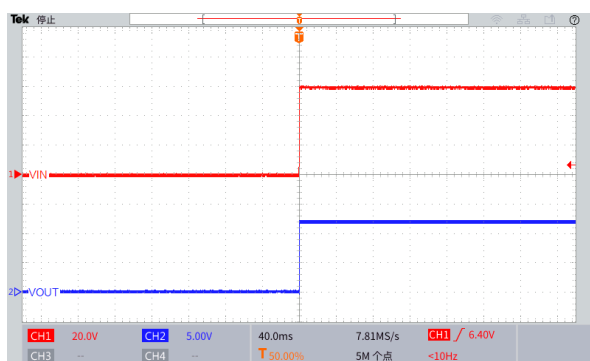

Figure 18. Start-Up Characteristic
($V_{IN}=60V$, $V_{OUT}=12V$, $I_{OUT}=0.1A$)

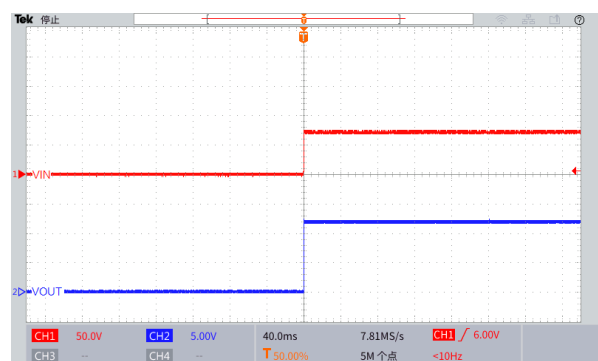

Figure 19. Start-Up Characteristic
($V_{IN}=72V$, $V_{OUT}=12V$, $I_{OUT}=0.1A$)

140kHz 80V 2A Buck DC to DC Converter

XL7058

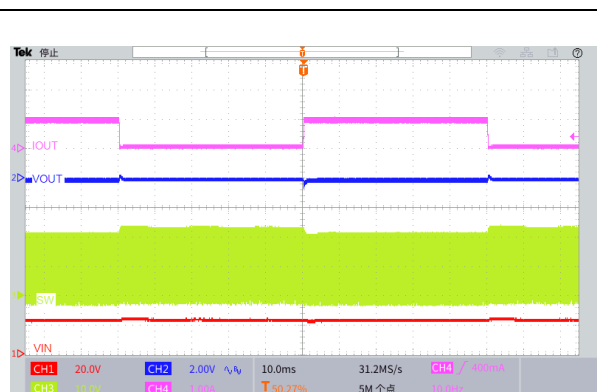

Figure 25. Load Transient Response
($V_{IN}=24V$, $V_{OUT}=12V$, $I_{OUT}=0.1$ to $1.0A$)

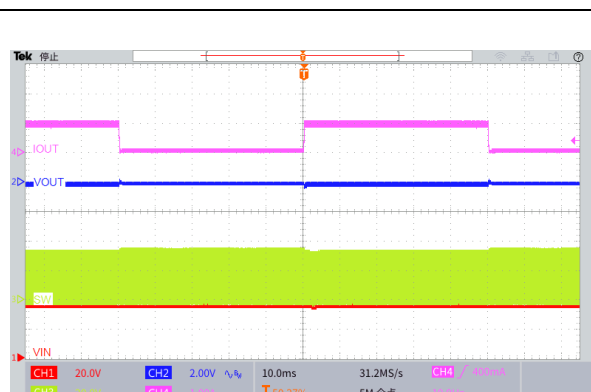

Figure 26. Load Transient Response
($V_{IN}=36V$, $V_{OUT}=12V$, $I_{OUT}=0.1$ to $1.0A$)

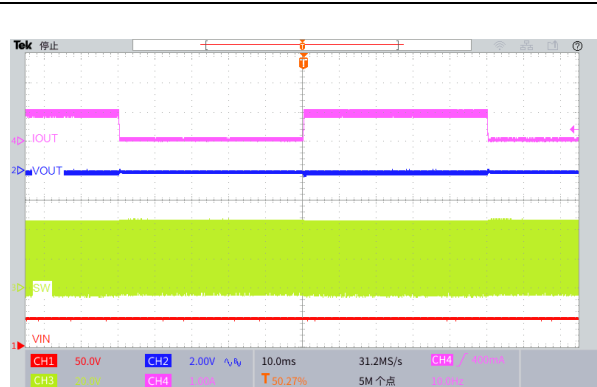

Figure 27. Load Transient Response
($V_{IN}=48V$, $V_{OUT}=12V$, $I_{OUT}=0.1$ to $1.0A$)

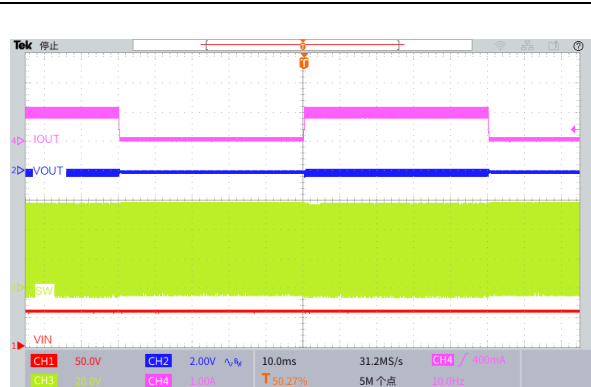

Figure 28. Load Transient Response
($V_{IN}=60V$, $V_{OUT}=12V$, $I_{OUT}=0.1$ to $1.0A$)

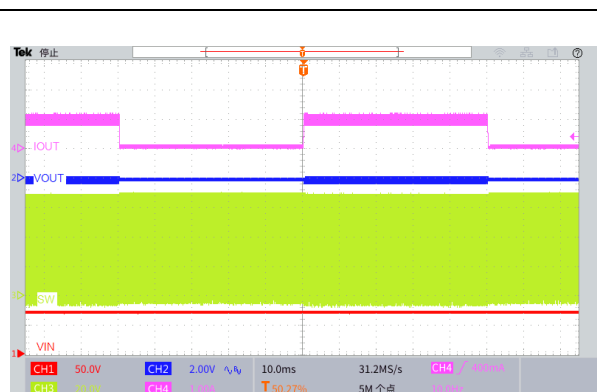
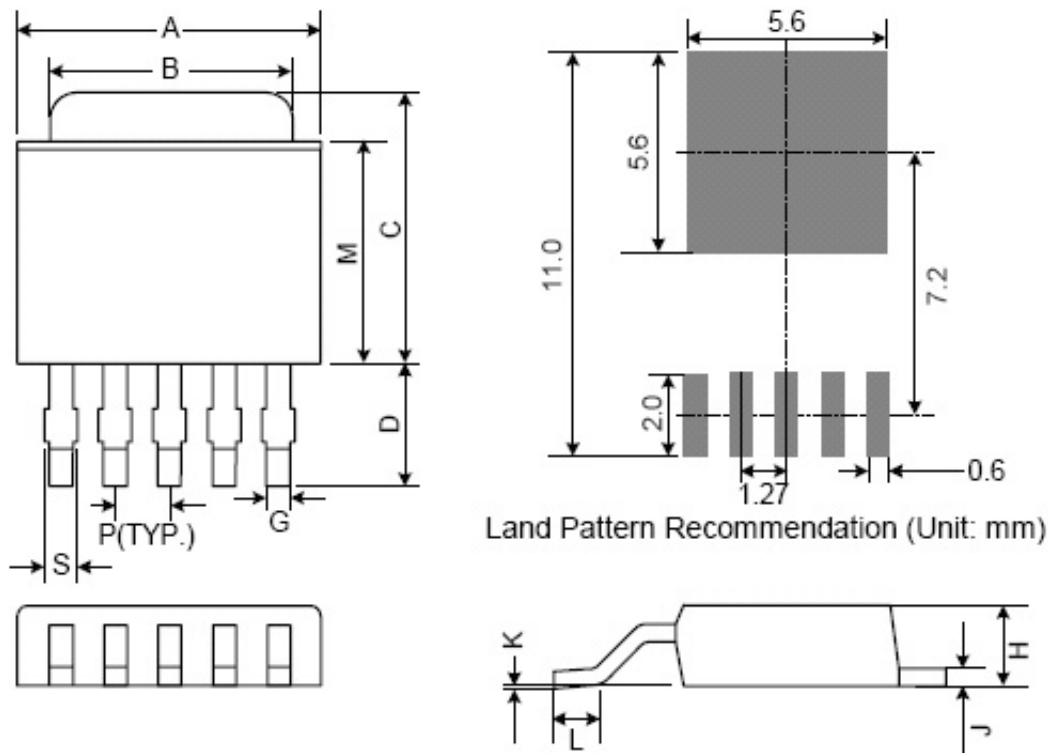

Figure 29. Load Transient Response
($V_{IN}=72V$, $V_{OUT}=12V$, $I_{OUT}=0.1$ to $1.0A$)

Package Information

TO252-5L



Symbol	Dimensions In Millimeters			Dimensions In Inches		
	Min.	Nom.	Max.	Min.	Nom.	Max.
A	6.35	6.60	6.85	0.250	0.260	0.270
B	5.20	5.35	5.50	0.205	0.211	0.217
C	6.80	7.00	7.30	0.268	0.276	0.287
D	2.40	2.80	3.20	0.094	0.110	0.126
P	1.27 REF			0.05 REF		
S	0.50	0.65	0.80	0.020	0.026	0.031
G	0.40	0.50	0.63	0.016	0.020	0.025
H	2.20	2.30	2.40	0.087	0.091	0.094
J	0.45	0.52	0.58	0.018	0.020	0.023
K	0.00	0.08	0.15	0.000	0.003	0.006
L	0.90	1.20	1.77	0.035	0.047	0.064
M	5.40	5.80	6.20	0.213	0.228	0.244

140kHz 80V 2A Buck DC to DC Converter	XL7058
---------------------------------------	--------

Important Notice

XLSEMI reserve the right to make modifications, enhancements, improvements, corrections or other changes without notice at any time. XLSEMI does not assume any liability arising out of the application or use of any product described herein; neither does it convey any license under its patent rights, nor the rights of others. XLSEMI assumes no liability for applications assistance or the design of Buyers' products. Buyers are responsible for their products and applications using XLSEMI components. To minimize the risks associated with Buyers' products and applications, Buyers should provide adequate design and operating safeguards. XLSEMI warrants performance of its products to the specifications applicable at the time of sale, in accordance with the warranty in XLSEMI's terms and conditions of sale of semiconductor products. Testing and other quality control techniques are used to the extent XLSEMI deems necessary to support this warranty. Except where mandated by applicable law, testing of all parameters of each component is not necessarily performed.

For the latest product information, go to www.xlsemi.com.