

## 3.0A 200KHz 50V Synchronous Buck DC to DC Converter With CV/CC Loop XL9005

### Features

- Operation Voltage: 5V~45V
- Output Adjustable from 1.25V to 40V
- Maximum Duty Cycle up to 100%
- Feedback Voltage Accuracy  $\pm 2\%$
- Fixed 200KHz Switching Frequency
- 3.0A Constant Output Current Capability
- Internal Optimize Power MOSFET
- High efficiency up to 95%
- Max. Output power up to 15W
- Excellent line and load regulation
- Built in thermal shutdown function
- Built in current limit protection function
- Built in output short protection function
- Built in constant voltage loop and constant current loop
- Temperature Grade 1:  $-40^{\circ}\text{C}$  to  $125^{\circ}\text{C}$  Ambient Operating Temperature Range
- Device HBM ESD Classification Level Class3A
- Available in SOP8-EP package

### General Description

The XL9005 is a 200KHz fixed frequency PWM synchronous buck DC/DC converter, capable of driving a 3.0A load with high efficiency, low ripple and excellent line and load regulation. XL9005 supports wide input operating voltage range of 5V ~ 45V and a maximum duty cycle of 100% output. Output supports constant voltage loop and constant current loop. A built-in loop compensation module reduces components in the system, lowering power system cost and reducing printed circuit board space. The XL9005 has built-in thermal shutdown, current limit protection and output short protection function and so on. When the output short protection function happens, the operation frequency will be reduced about from 200KHz to 30KHz.

### Applications

- Automotive Electronics
- Industrial Control
- Networking Equipment
- Internet of Things

### Typical application schematic

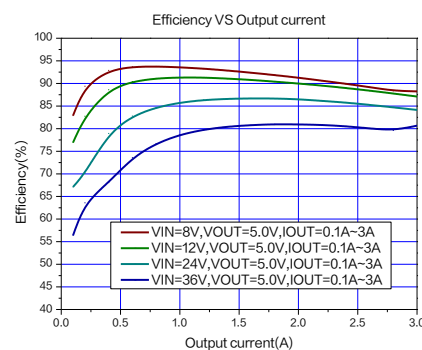
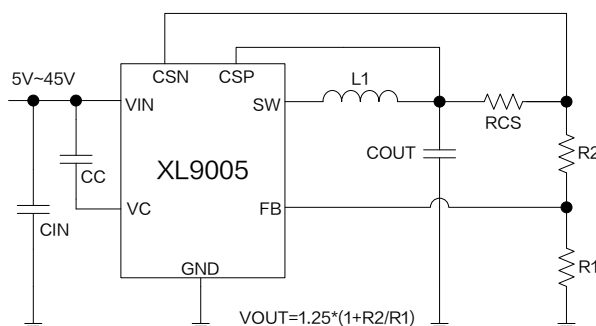

Figure1. XL9005 Typical application schematic and efficiency curve

## 3.0A 200KHz 50V Synchronous Buck DC to DC Converter With CV/CC Loop XL9005

### Pin Configurations

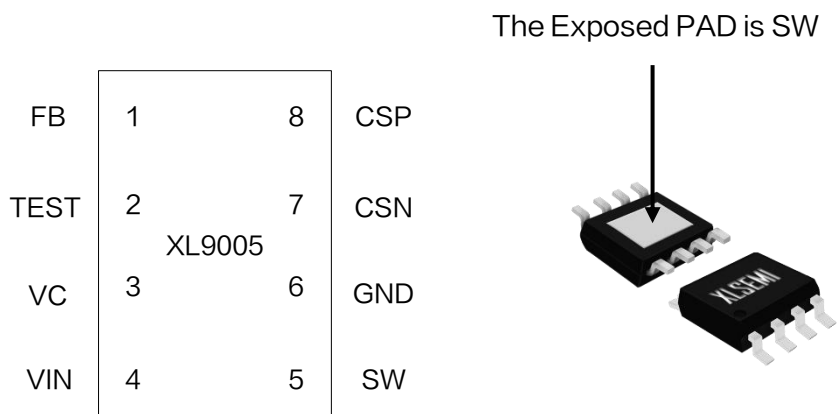

Figure2. Pin Configuration of XL9005

Table 1 Pin Description

Pin Number	Pin Name	Description
1	FB	Feedback Pin (FB). Through an external resistor divider network, Feedback senses the output voltage and regulates it. The feedback threshold voltage is 1.25V.
2	TEST	IC Internal Test Pin. Floating in system application.
3	VC	Internal Voltage Regulator Bypass Capacity. In typical system application, The VC pin connect a 1uF capacitor to VIN.
4	VIN	Supply Voltage Input Pin. XL9005 operates from 5V to 45V DC voltage. Bypass Vin to GND with a suitably large capacitor to eliminate noise on the input.
5	SW	Power Switch Output Pin (SW). Output is the switch node that supplies power to the output.
6	GND	Ground Pin.
7	CSN	Current detection negative terminal pin.
8	CSP	Current detection positive terminal pin.

### Ordering Information

Order Information	Marking ID	Package Type	Eco Plan	Packing Type Supplied As
XL9005E1	XL9005E1	SOP8-EP	RoHS & HF	4000 Units on Reel

## 3.0A 200KHz 50V Synchronous Buck DC to DC Converter With CV/CC Loop XL9005

### Function Block

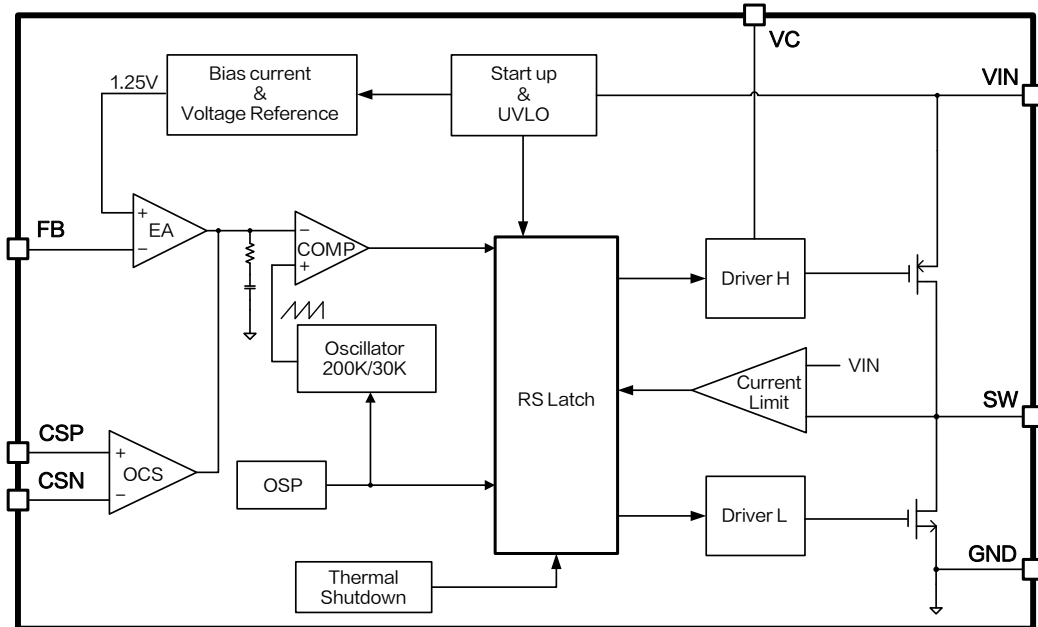

Figure3. Function Block Diagram of XL9005

### Absolute Maximum Ratings ( Note1 )

Parameter	Symbol	Value	Unit
Input Voltage	$V_{IN}$	-0.3~50	V
Internal Voltage Regulator Bypass Capacity.	$V_C$	-0.3~ $V_{IN}$	V
Feedback Pin Voltage	$V_{FB}$	-0.3~7	V
Output Switch Pin Voltage	$V_{SW}$	-0.3~ $V_{IN}$	V
CSP Pin Voltage	$V_{CSP}$	-0.3~45	V
CSN Pin Voltage	$V_{CSN}$	-0.3~45	V
Power Dissipation	$P_D$	Internally limited	mW
Thermal Resistance (SOP8-EP) (Junction to Ambient, No Heatsink, Free Air)	$R_{JA}$	60	°C/W
Operating Junction Temperature	$T_J$	-40~150	°C
Storage Temperature	$T_{STG}$	-65~150	°C
Lead Temperature (Soldering, 10 sec)	$T_{LEAD}$	260	°C
ESD (HBM)		>4000	V

**Note1:** Stresses greater than those listed under Maximum Ratings may cause permanent damage to the device. This is a stress rating only and functional operation of the device at these or any other conditions above those indicated in the operation is not implied. Exposure to absolute maximum rating conditions for extended periods may affect reliability.

## 3.0A 200KHz 50V Synchronous Buck DC to DC Converter With CV/CC Loop XL9005

### XL9005 Electrical Characteristics

$T_A = 25^\circ\text{C}$ ; system parameters test circuit figure6, unless otherwise specified.

Symbol	Parameter	Test Condition	Min.	Typ.	Max.	Unit
$V_{FB}$	Feedback Voltage	$V_{IN}=12V, V_{OUT}=5.0V$ $I_{OUT}=0.5A$	1.225	1.25	1.275	V
$\eta$	Efficiency	$V_{IN}=12V, V_{OUT}=3.3V$ $I_{OUT}=1.0A$	-	87.7	-	%
$\eta$	Efficiency	$V_{IN}=12V, V_{OUT}=5.0V$ $I_{OUT}=1.0A$	-	91.3	-	%
$\eta$	Efficiency	$V_{IN}=24V, V_{OUT}=12V$ $I_{OUT}=1.0A$	-	93.3	-	%
$\eta$	Efficiency	$V_{IN}=24V, V_{OUT}=15V$ $I_{OUT}=1.0A$	-	94.7	-	%

### Electrical Characteristics (DC Parameters)

$T_A=25^\circ\text{C}, V_{IN}=12V$ ; system parameters test circuit figure6, unless otherwise specified.

Parameters	Symbol	Test Condition	Min.	Typ.	Max.	Unit
Input operation voltage	$V_{IN}$		5		45	V
Quiescent Supply Current	$I_Q$	$V_{FB}=2V$		3	5	mA
Oscillator Frequency	$F_{OSC}$		170	200	230	KHz
Switch Current Limit	$I_L$	$V_{FB}=0$		3		A
High side MOS On-resistance	$R_{DS(ON)H}$			68		$m\Omega$
Low side MOS On-resistance	$R_{DS(ON)L}$			50		$m\Omega$
Thermal Shutdown Temperature	$T_{SD}$			160		$^\circ\text{C}$
Maximum Duty Cycle	$D_{MAX}$			100		%

## 3.0A 200KHz 50V Synchronous Buck DC to DC Converter With CV/CC Loop XL9005

### Typical System Application Schematic ( $V_{OUT}=3.3V$ , $I_{OUT}=0\sim 3.0A$ )

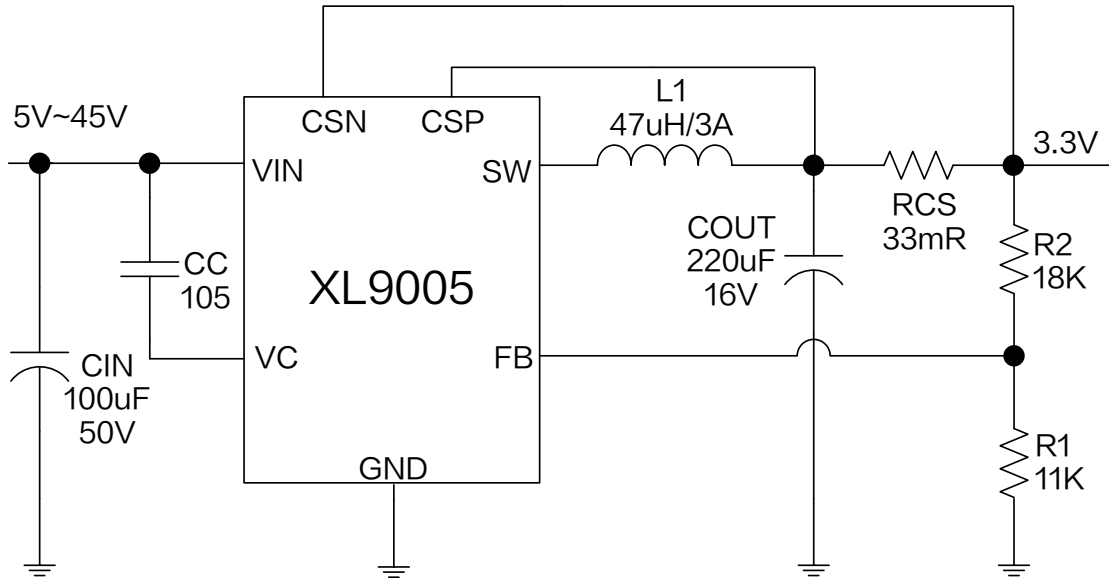

Figure4. XL9005 System Application ( $V_{IN}=5V\sim 45V$ ,  $V_{OUT}=3.3V$ ,  $I_{OUT}=0\sim 3.0A$ )

### Typical System Application Transfer Efficiency

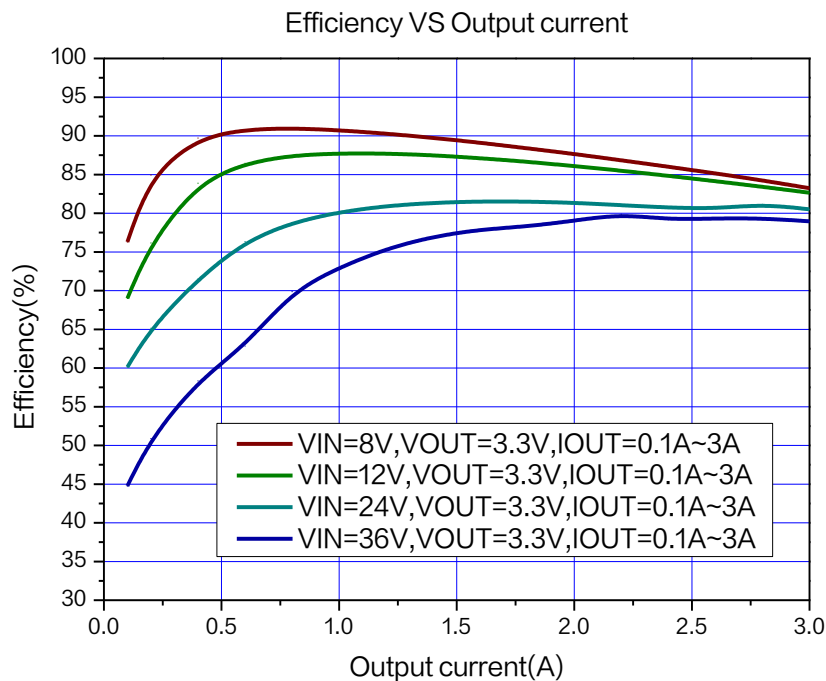

Figure5. XL9005 System Efficiency Curve ( $V_{OUT}=3.3V$ )

## 3.0A 200KHz 50V Synchronous Buck DC to DC Converter With CV/CC Loop XL9005

### Typical System Application Schematic ( $V_{OUT}=5.0V$ , $I_{OUT}=0\sim 3.0A$ )

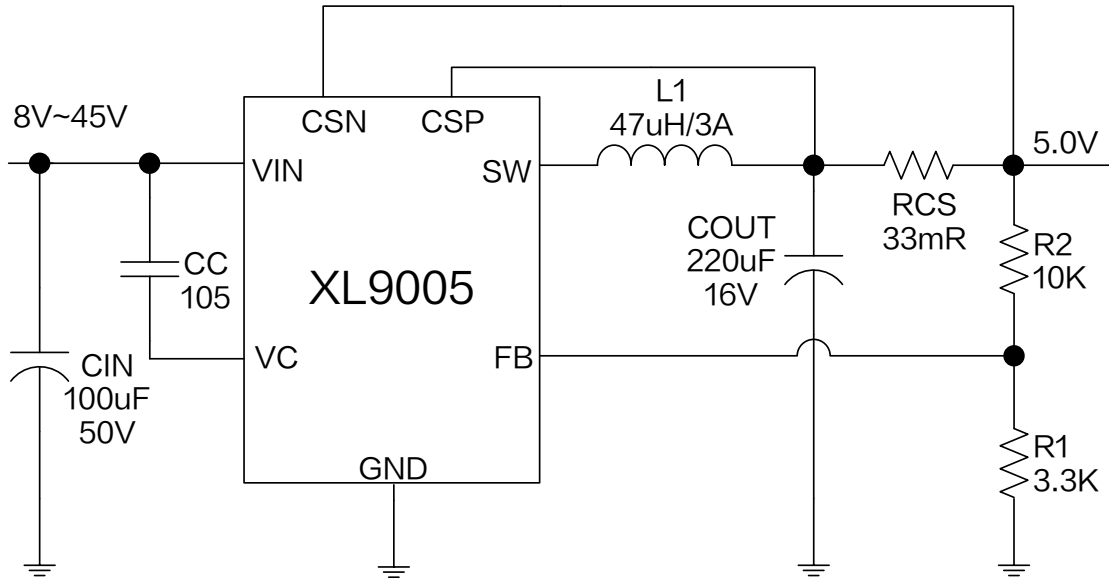

Figure6. XL9005 System Application ( $V_{IN}=8V\sim 45V$ ,  $V_{OUT}=5.0V$ ,  $I_{OUT}=0\sim 3.0A$ )

### Typical System Application Transfer Efficiency

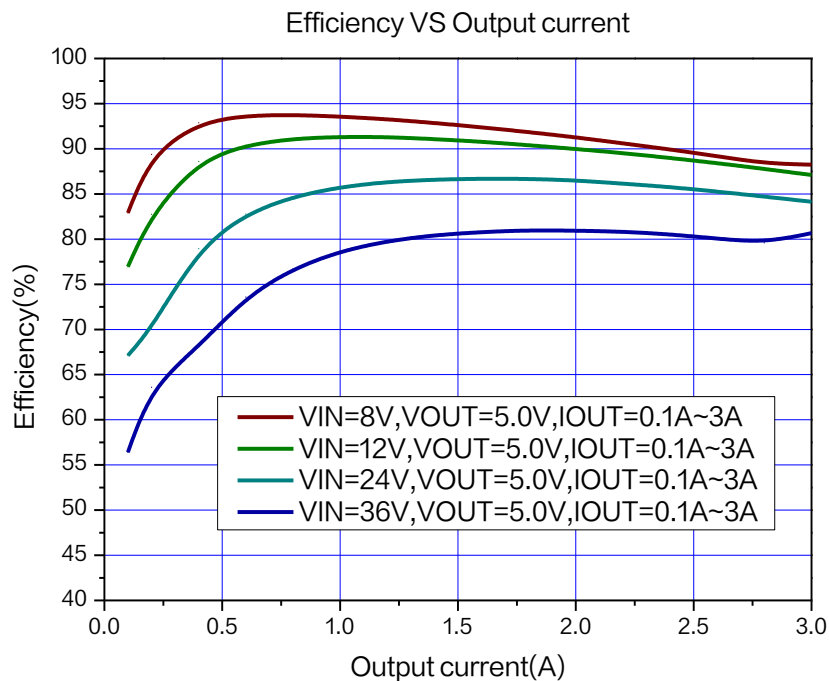

Figure7. XL9005 System Efficiency Curve ( $V_{OUT}=5.0V$ )

## 3.0A 200KHz 50V Synchronous Buck DC to DC Converter With CV/CC Loop XL9005

### Typical System Application Schematic ( $V_{OUT}=12V, I_{OUT}=0\sim 2.0A$ )

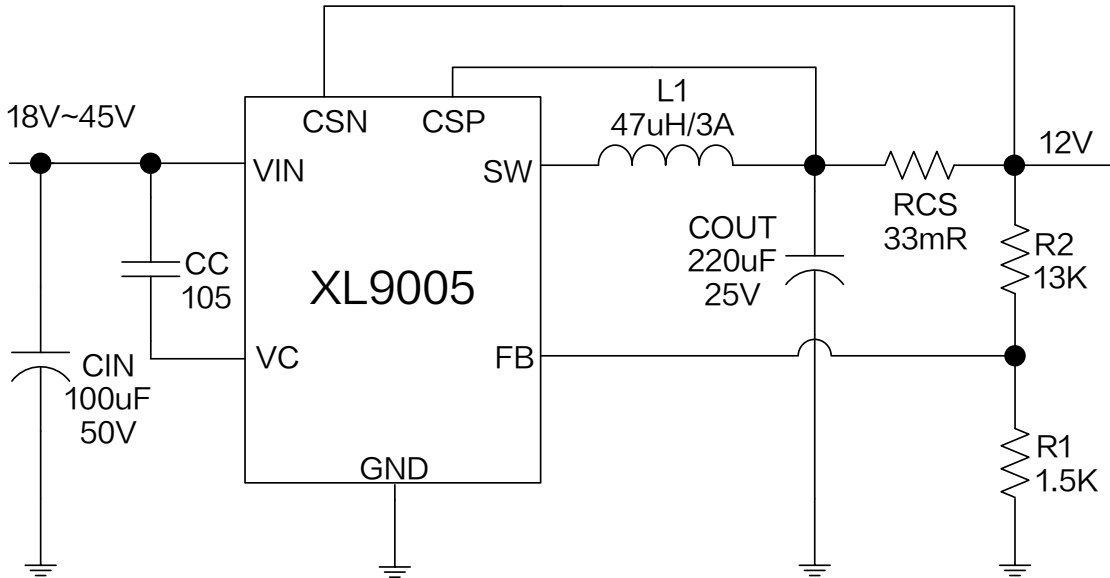

Figure8. XL9005 System Parameters Test Circuit ( $V_{IN}=18V\sim 45V, V_{OUT}=12V, I_{OUT}=0\sim 2.0A$ )

### Typical System Application Transfer Efficiency

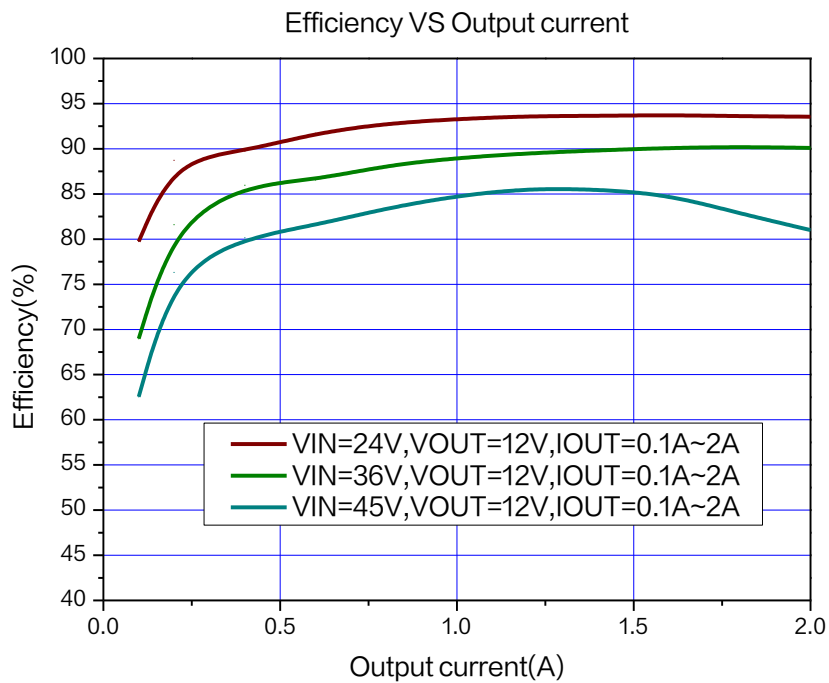

Figure9. XL9005 System Efficiency Curve ( $V_{OUT}=12V$ )

## 3.0A 200KHz 50V Synchronous Buck DC to DC Converter With CV/CC Loop XL9005

### Typical Characteristics

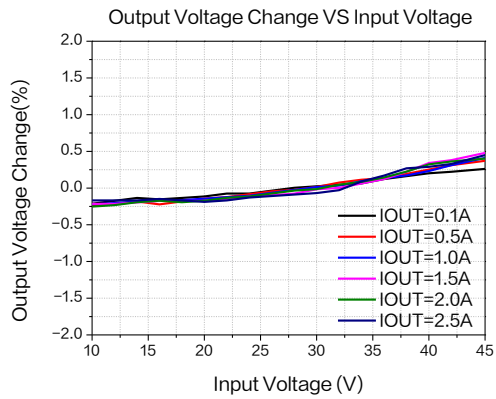

Figure10.Line Regulation

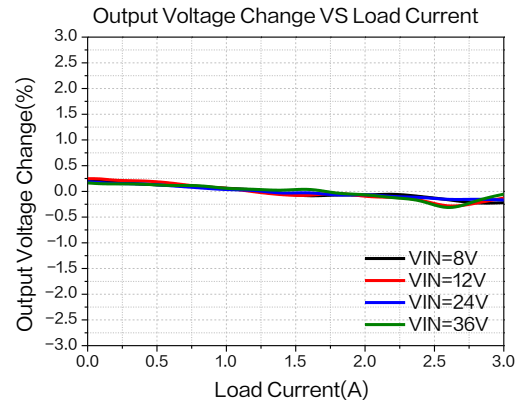

Figure11.Load Regulation

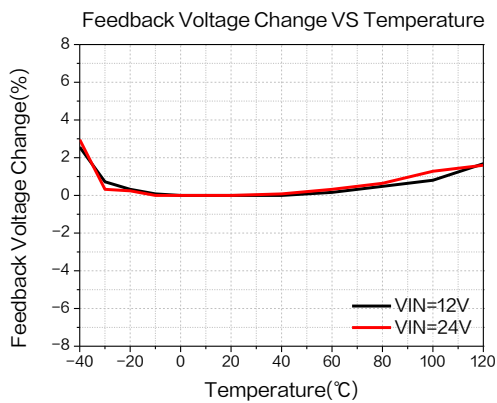

Figure12.Feedback Voltage Regulation

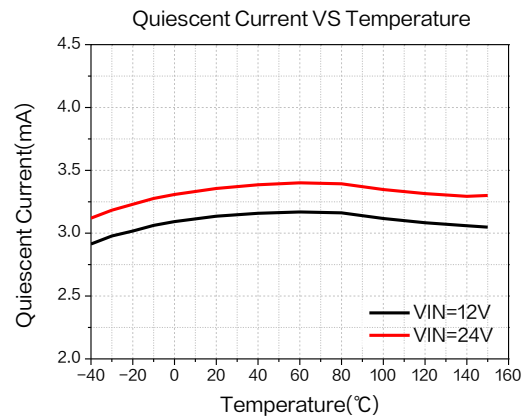

Figure13.Quiescent Current



## 3.0A 200KHz 50V Synchronous Buck DC to DC Converter With CV/CC Loop XL9005

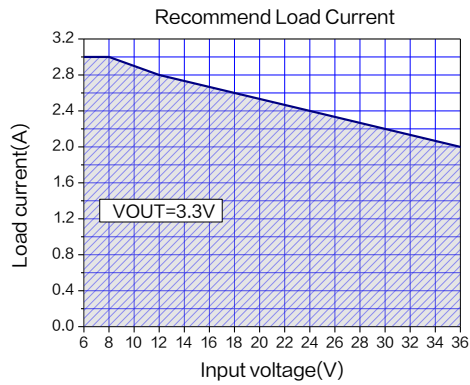

Figure 14. Max Output Current  
(V<sub>OUT</sub>=3.3V, T<sub>A</sub>=25°C)

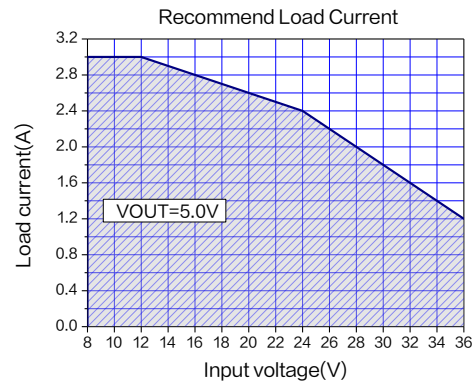

Figure 15. Max Output Current  
(V<sub>OUT</sub>=5.0V, T<sub>A</sub>=25°C)

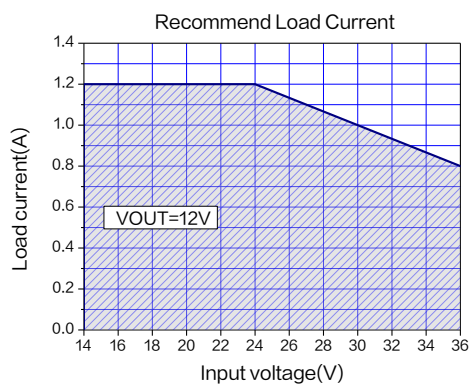

Figure 16. Max Output Current  
(V<sub>OUT</sub>=12V, T<sub>A</sub>=25°C)

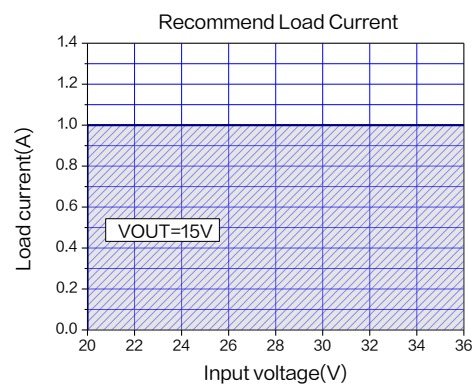

Figure 17. Max Output Current  
(V<sub>OUT</sub>=15V, T<sub>A</sub>=25°C)

## 3.0A 200KHz 50V Synchronous Buck DC to DC Converter With CV/CC Loop XL9005

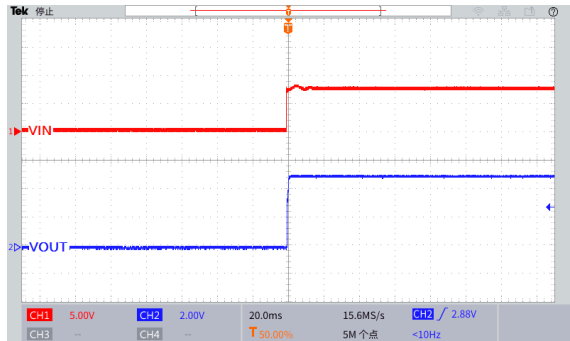

Figure 18. Start-Up Characteristic  
( $V_{IN}=8V$ ,  $V_{OUT}=5.0V$ ,  $I_{OUT}=0.1A$ )

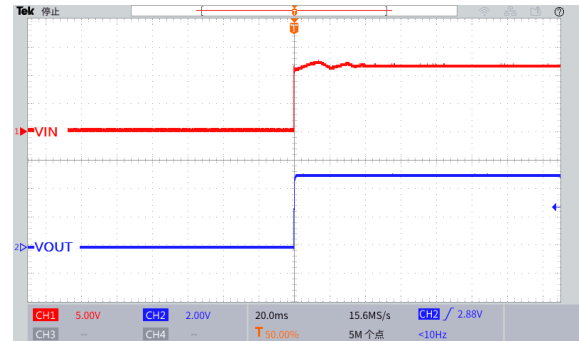

Figure 19. Start-Up Characteristic  
( $V_{IN}=12V$ ,  $V_{OUT}=5.0V$ ,  $I_{OUT}=0.1A$ )

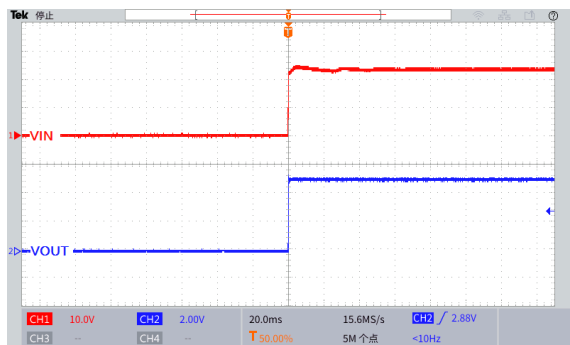

Figure 20. Start-Up Characteristic  
( $V_{IN}=24V$ ,  $V_{OUT}=5.0V$ ,  $I_{OUT}=0.1A$ )

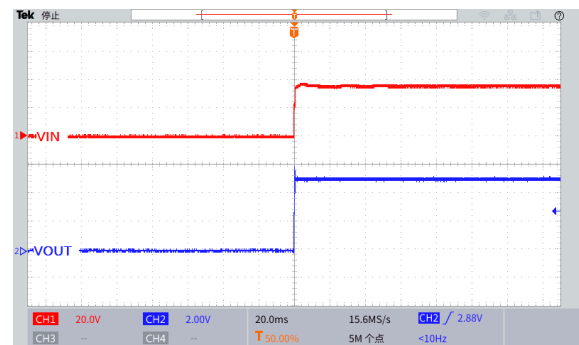

Figure 21. Start-Up Characteristic  
( $V_{IN}=36V$ ,  $V_{OUT}=5.0V$ ,  $I_{OUT}=0.1A$ )

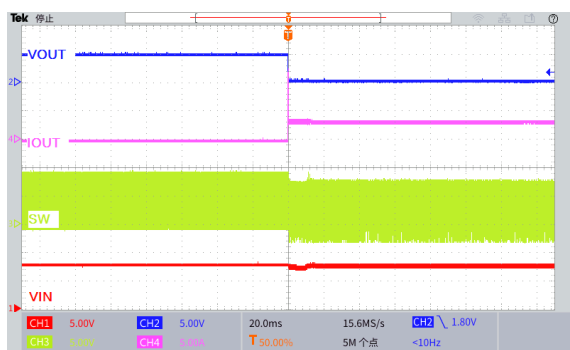

Figure 22. Output Short Circuit Waveform  
( $V_{IN}=8V$ ,  $V_{OUT}=5.0V$ )

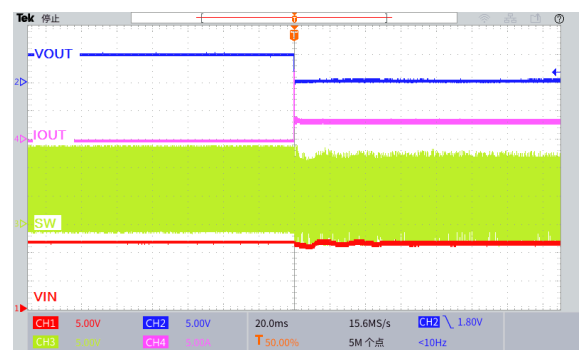

Figure 23. Output Short Circuit Waveform  
( $V_{IN}=12V$ ,  $V_{OUT}=5.0V$ )

## 3.0A 200KHz 50V Synchronous Buck DC to DC Converter With CV/CC Loop XL9005

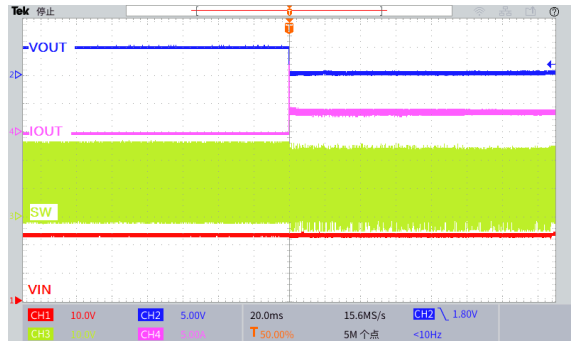

Figure 24. Output Short Circuit Waveform  
( $V_{IN}=24V$ ,  $V_{OUT}=5.0V$ )



Figure 25. Output Short Circuit Waveform  
( $V_{IN}=36V$ ,  $V_{OUT}=5.0V$ )

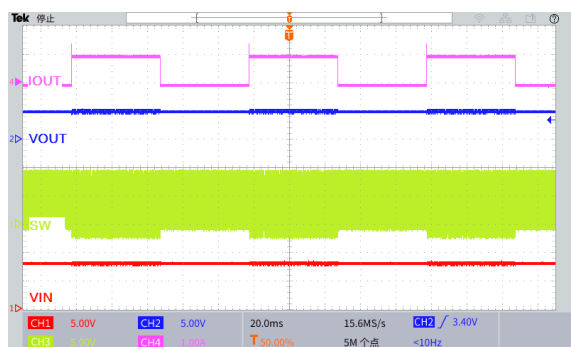

Figure 26. Load Transient Response  
( $V_{IN}=8V$ ,  $V_{OUT}=5.0V$ ,  $I_{OUT}=0$  to 1A)

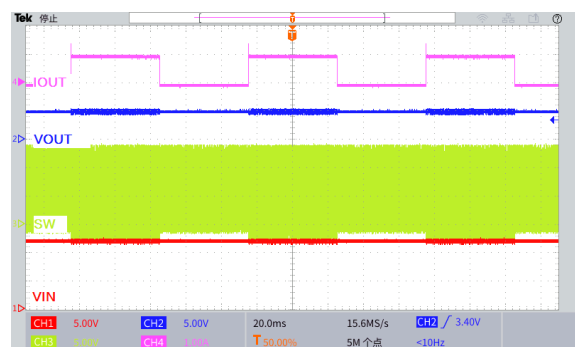

Figure 27. Load Transient Response  
( $V_{IN}=12V$ ,  $V_{OUT}=5.0V$ ,  $I_{OUT}=0$  to 1A)

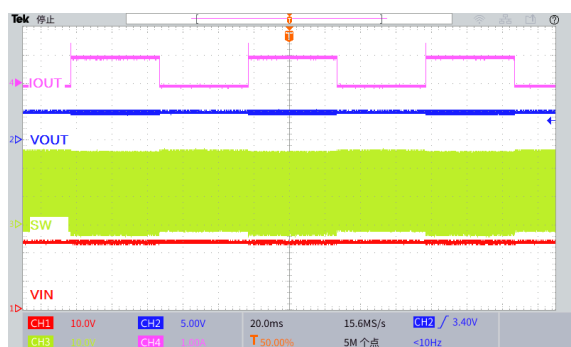

Figure 28. Load Transient Response  
( $V_{IN}=24V$ ,  $V_{OUT}=5.0V$ ,  $I_{OUT}=0$  to 1A)

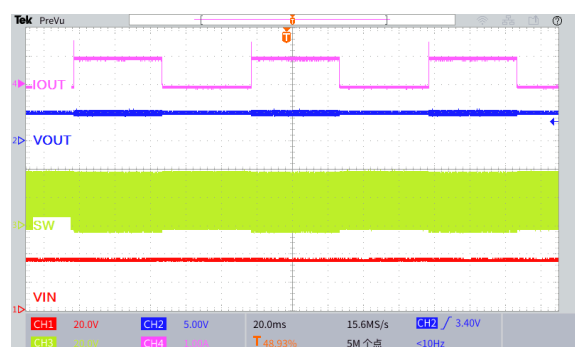
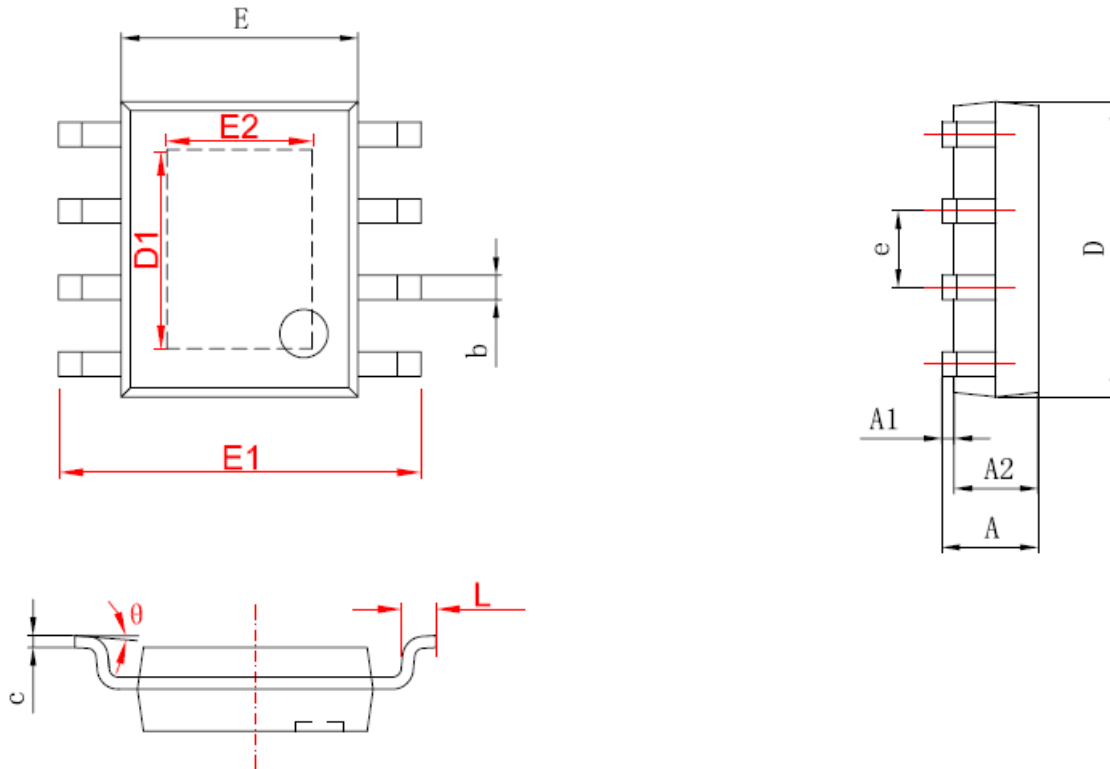

Figure 29. Load Transient Response  
( $V_{IN}=36V$ ,  $V_{OUT}=5.0V$ ,  $I_{OUT}=0$  to 1A)

## 3.0A 200KHz 50V Synchronous Buck DC to DC Converter With CV/CC Loop XL9005

### Package Information

#### SOP8-EP



Symbol	Dimensions In Millimeters		Dimensions In Inches	
	Min	Max	Min	Max
A	1.350	1.750	0.053	0.069
A1	0.050	0.150	0.004	0.010
A2	1.350	1.550	0.053	0.061
b	0.330	0.510	0.013	0.020
c	0.170	0.250	0.006	0.010
D	4.700	5.100	0.185	0.200
D1	3.202	3.402	0.126	0.134
E	3.800	4.000	0.150	0.157
E1	5.800	6.200	0.228	0.244
E2	2.313	2.513	0.091	0.099
e	1.270(BSC)		0.050(BSC)	
L	0.400	1.270	0.016	0.050
$\theta$	0°	8°	0°	8°

---

**3.0A 200KHz 50V Synchronous Buck DC to DC Converter With CV/CC Loop XL9005**

---

**Important Notice**

XLSEMI reserve the right to make modifications, enhancements, improvements, corrections or other changes without notice at any time. XLSEMI does not assume any liability arising out of the application or use of any product described herein; neither does it convey any license under its patent rights, nor the rights of others. XLSEMI assumes no liability for applications assistance or the design of Buyers' products. Buyers are responsible for their products and applications using XLSEMI components. To minimize the risks associated with Buyers' products and applications, Buyers should provide adequate design and operating safeguards. XLSEMI warrants performance of its products to the specifications applicable at the time of sale, in accordance with the warranty in XLSEMI's terms and conditions of sale of semiconductor products. Testing and other quality control techniques are used to the extent XLSEMI deems necessary to support this warranty. Except where mandated by applicable law, testing of all parameters of each component is not necessarily performed.

For the latest product information, go to [www.xlsemi.com](http://www.xlsemi.com).