

2.0A 200KHz 50V Synchronous Buck DC to DC Converter With CV/CC Loop XL9009

Features

- Operation Voltage: 5V~45V
- Output Adjustable from 1.25V to 40V
- Feedback Voltage Accuracy $\pm 2\%$
- Fixed 200KHz Switching Frequency
- 2.0A Constant Output Current Capability
- Internal Optimize Power MOSFET
- High efficiency up to 93%
- Max. Output power up to 12W
- Excellent line and load regulation
- EN PIN TTL ON/OFF capability
- Built in thermal shutdown function
- Built in current limit protection function
- Built in output short protection function
- Built in constant voltage loop and constant current loop
- Temperature Grade 1: -40°C to 125°C Ambient Operating Temperature Range
- Device HBM ESD Classification Level Class3A
- Available in SOP8-EP package

General Description

The XL9009 is a 200KHz fixed frequency PWM synchronous buck DC/DC converter, capable of driving a 2.0A load with high efficiency, low ripple and excellent line and load regulation. XL9009 supports wide input operating voltage range of 5V ~ 45V and a maximum duty cycle of 100% output. Output supports constant voltage loop and constant current loop. A built-in loop compensation module reduces components in the system, lowering power system cost and reducing printed circuit board space. The XL9009 has built-in TTL ON/OFF capability, thermal shutdown, current limit protection and output short protection function and so on. When the output short protection function happens, the operation frequency will be reduced about from 200KHz to 50KHz.

Applications

- Automotive Electronics
- Industrial Control
- Networking Equipment
- Internet of Things

Typical application schematic

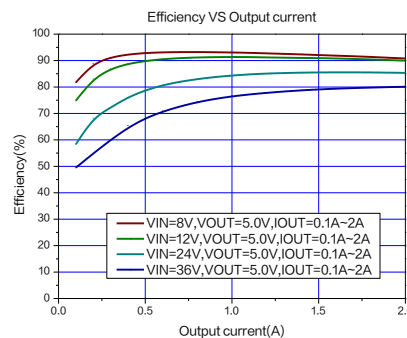
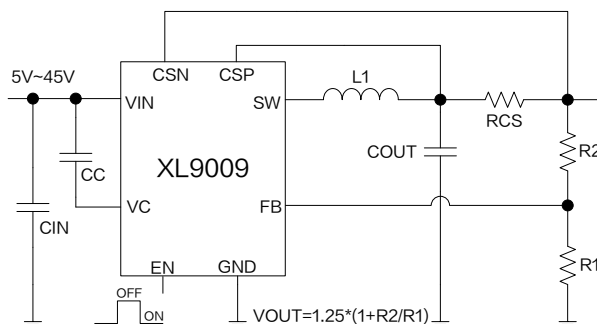

Figure1. XL9009 Typical application schematic and efficiency curve

2.0A 200KHz 50V Synchronous Buck DC to DC Converter With CV/CC Loop XL9009

Pin Configurations

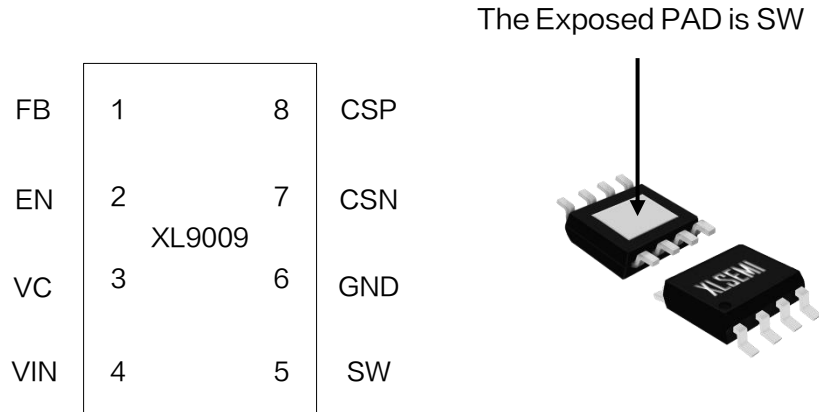

Figure2. Pin Configuration of XL9009

Table 1 Pin Description

Pin Number	Pin Name	Description
1	FB	Feedback Pin (FB). Through an external resistor divider network, Feedback senses the output voltage and regulates it. The feedback threshold voltage is 1.25V.
2	EN	Enable Pin. Drive EN pin high to turn on the device, drive it low to turn it off. Floating is default high.
3	VC	Internal Voltage Regulator Bypass Capacity. In typical system application, The VC pin connect a 1uF capacitor to VIN.
4	VIN	Supply Voltage Input Pin. XL9009 operates from 5V to 45V DC voltage. Bypass Vin to GND with a suitably large capacitor to eliminate noise on the input.
5	SW	Power Switch Output Pin (SW). Output is the switch node that supplies power to the output.
6	GND	Ground Pin.
7	CSN	Current detection negative terminal pin.
8	CSP	Current detection positive terminal pin.

Ordering Information

Order Information	Marking ID	Package Type	Eco Plan	Packing Type Supplied As
XL9009	XL9009	SOP8-EP	RoHS & HF	4000 Units on Reel

2.0A 200KHz 50V Synchronous Buck DC to DC Converter With CV/CC Loop XL9009

Function Block

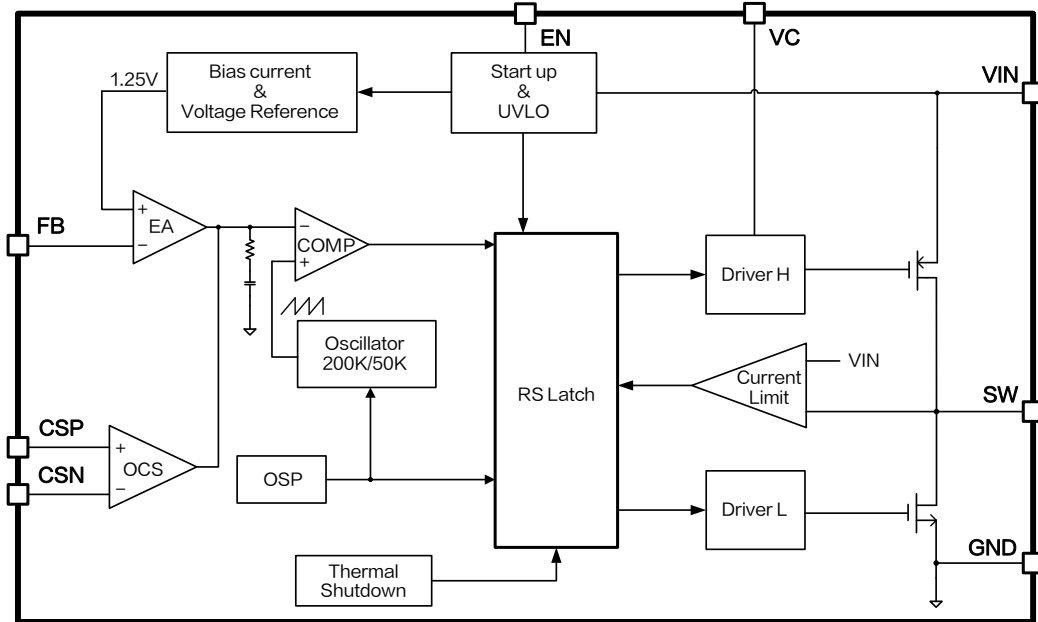

Figure3. Function Block Diagram of XL9009

Absolute Maximum Ratings (Note1)

Parameter	Symbol	Value	Unit
Input Voltage	V_{IN}	-0.3~50	V
EN Pin Voltage	V_{EN}	-0.3~7	V
Feedback Pin Voltage	V_{FB}	-0.3~7	V
Output Switch Pin Voltage	V_{SW}	-0.3~ V_{IN}	V
Internal Voltage Regulator Bypass Capacity	V_C	-0.3~ V_{IN}	V
CSP Pin Voltage	V_{CSP}	-0.3~ V_{IN}	V
CSN Pin Voltage	V_{CSN}	-0.3~ V_{IN}	V
Power Dissipation	P_D	Internally limited	mW
Thermal Resistance (SOP8-EP) (Junction to Ambient, No Heatsink, Free Air)	R_{JA}	60	°C/W
Operating Junction Temperature	T_J	-40~150	°C
Storage Temperature	T_{STG}	-65~150	°C
Lead Temperature (Soldering, 10 sec)	T_{LEAD}	260	°C
ESD (HBM)		>6000	V

Note1: Stresses greater than those listed under Maximum Ratings may cause permanent damage to the device. This is a stress rating only and functional operation of the device at these or any other conditions above those indicated in the operation is not implied. Exposure to absolute maximum rating conditions for extended periods may affect reliability.

2.0A 200KHz 50V Synchronous Buck DC to DC Converter With CV/CC Loop XL9009

XL9009 Electrical Characteristics

T_A = 25°C; system parameters test circuit figure6, unless otherwise specified.

Symbol	Parameter	Test Condition	Min.	Typ.	Max.	Unit
V _{FB}	Feedback Voltage	V _{IN} =12V, V _{OUT} =5.0V I _{OUT} =0.5A	1.225	1.25	1.275	V
η	Efficiency	V _{IN} =12V, V _{OUT} =5.0V I _{OUT} =1.0A	-	91.4	-	%
η	Efficiency	V _{IN} =24V, V _{OUT} =12V I _{OUT} =1.0A	-	93.0	-	%
η	Efficiency	V _{IN} =24V, V _{OUT} =15V I _{OUT} =0.8A	-	93.6	-	%

Electrical Characteristics (DC Parameters)

T_A=25°C, V_{IN}=12V; system parameters test circuit figure6, unless otherwise specified.

Parameters	Symbol	Test Condition	Min.	Typ.	Max.	Unit
Input operation voltage	V _{IN}		5		45	V
Shutdown Supply Current	I _S	V _{EN} =2V		35	100	uA
Quiescent Supply Current	I _Q	V _{FB} =2V		2.5	5	mA
Oscillator Frequency	F _{OSC}		170	200	230	KHz
Switch Current Limit	I _L	V _{FB} =0V		2		A
EN Pin Threshold	V _{EN,H}	High(OFF)	1.4			V
	V _{EN,L}	Low(ON)			0.8	V
High side MOS On-resistance	R _{DS(ON)H}			68		mΩ
Low side MOS On-resistance	R _{DS(ON)L}			50		mΩ
Thermal Shutdown Temperature	T _{SD}			160		°C
Thermal Shutdown Hysteresis	T _D			30		°C
Maximum Duty Cycle	D _{MAX}	V _{FB} =0V			100	%

2.0A 200KHz 50V Synchronous Buck DC to DC Converter With CV/CC Loop XL9009

Typical System Application Schematic ($V_{OUT}=3.3V$, $I_{OUT}=0\sim 2.0A$)

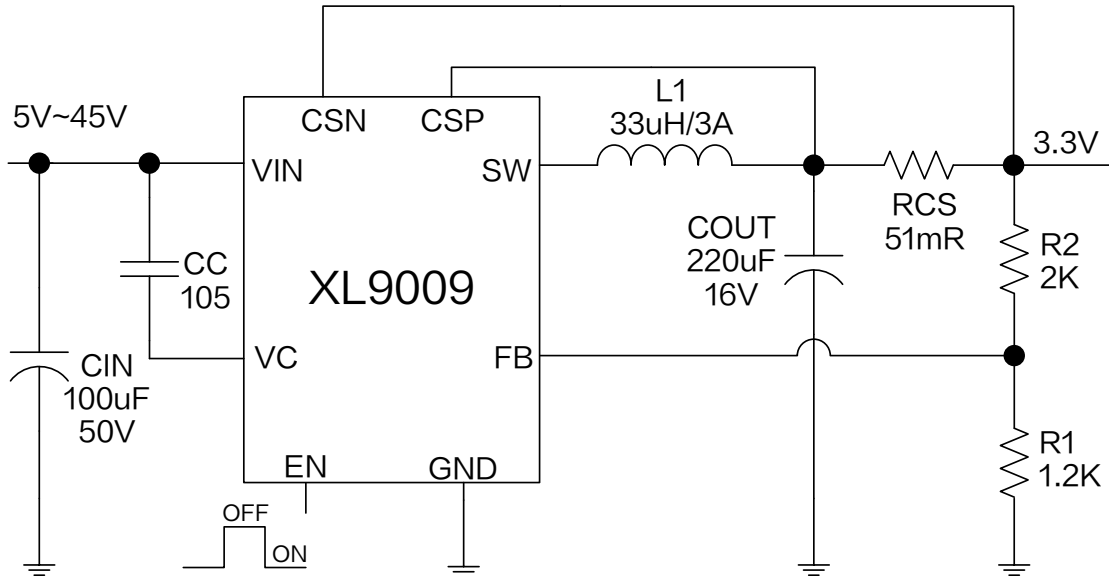

Figure4. XL9009 System Application ($V_{IN}=5V\sim 45V$, $V_{OUT}=3.3V$, $I_{OUT}=0\sim 2.0A$)

Typical System Application Transfer Efficiency

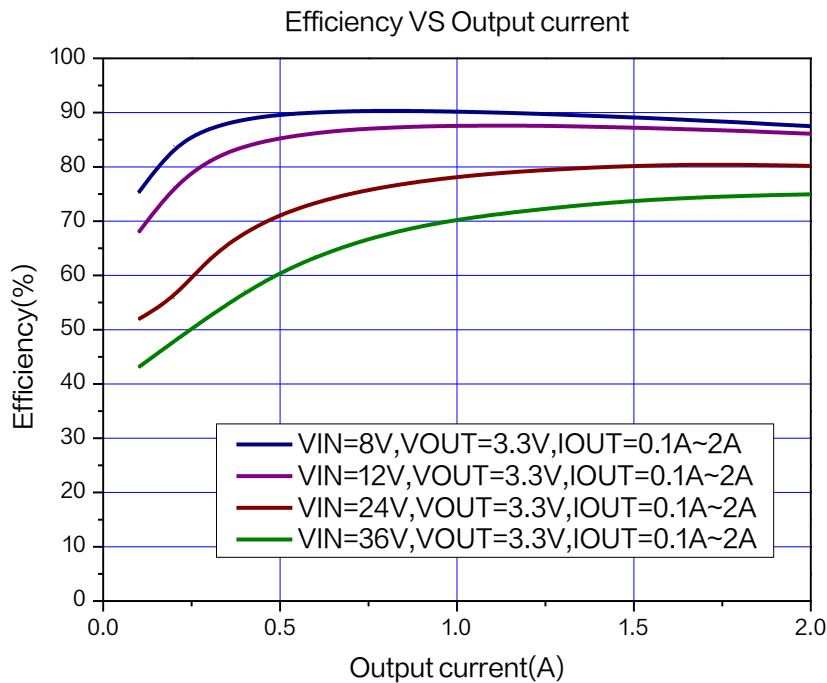

Figure5. XL9009 System Efficiency Curve ($V_{OUT}=3.3V$)

2.0A 200KHz 50V Synchronous Buck DC to DC Converter With CV/CC Loop XL9009

Typical System Application Schematic ($V_{OUT}=5.0V$, $I_{OUT}=0\sim 2.0A$)

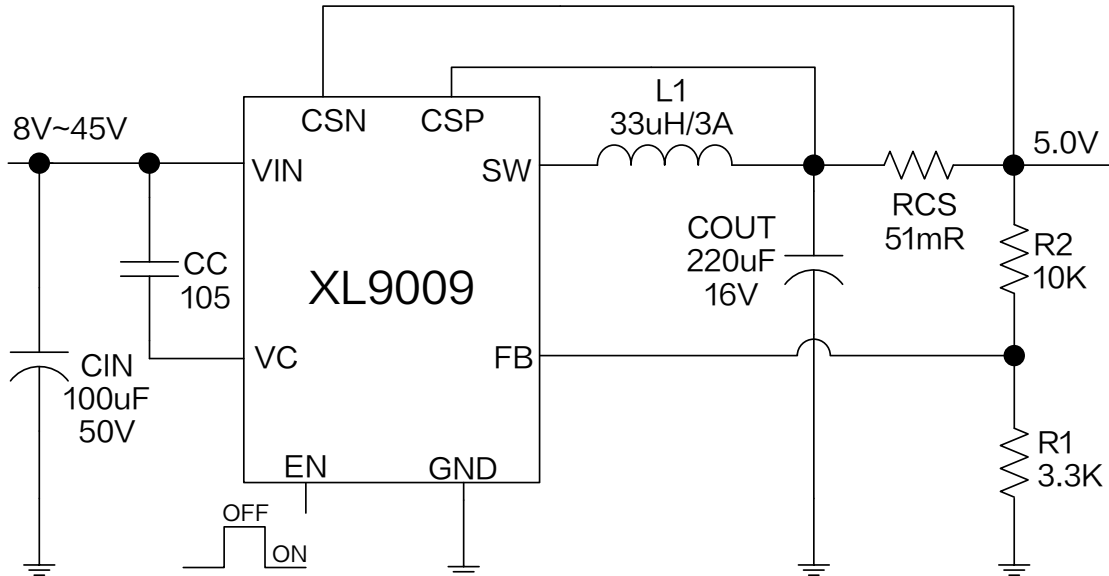

Figure6. XL9009 System Application ($V_{IN}=8V\sim 45V$, $V_{OUT}=5.0V$, $I_{OUT}=0\sim 2.0A$)

Typical System Application Transfer Efficiency

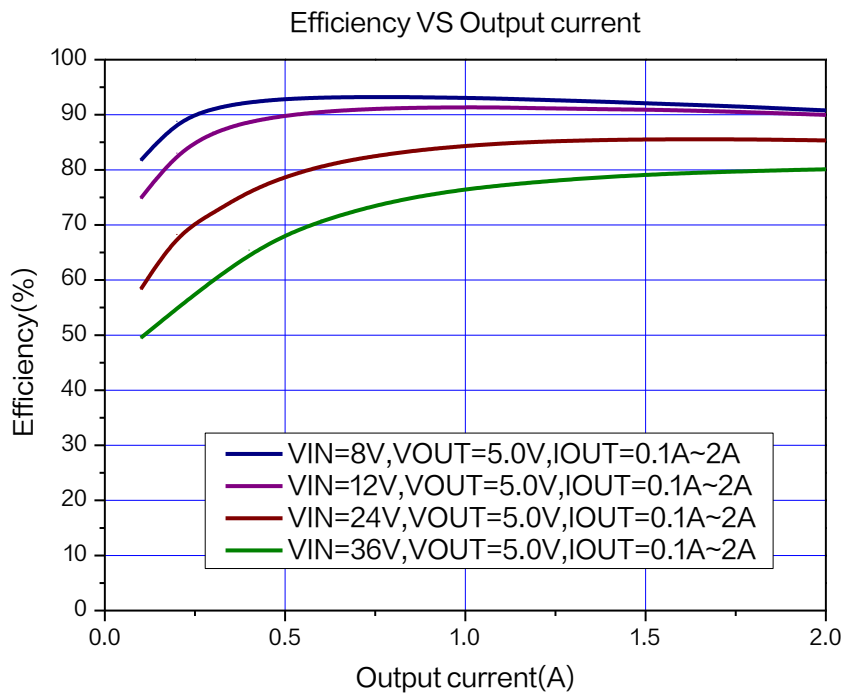

Figure7. XL9009 System Efficiency Curve ($V_{OUT}=5.0V$)

2.0A 200KHz 50V Synchronous Buck DC to DC Converter With CV/CC Loop XL9009

Typical System Application Schematic ($V_{OUT}=12V$, $I_{OUT}=0\sim 1.0A$)

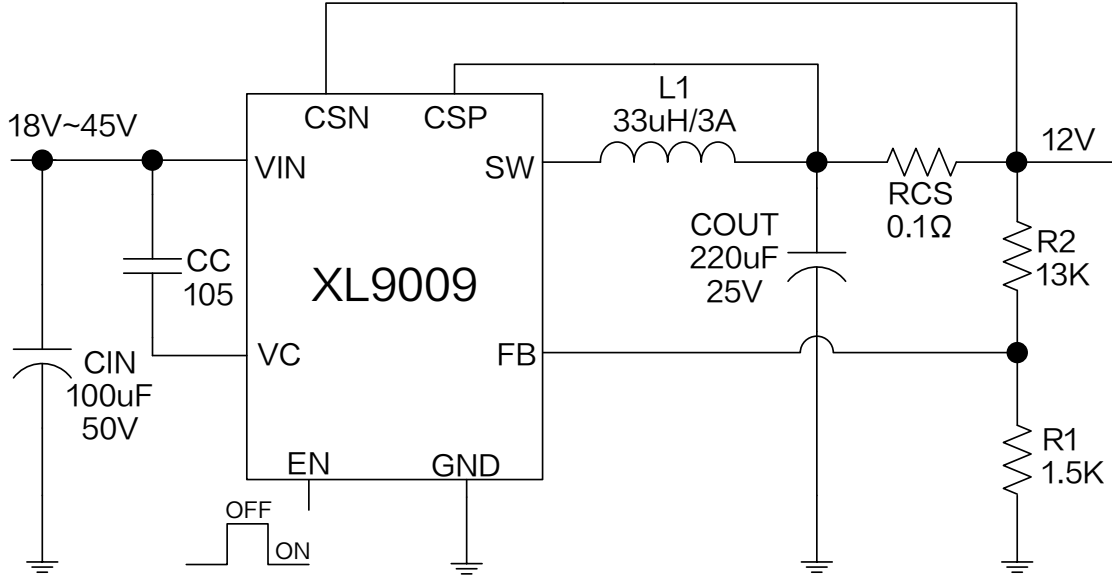

Figure8. XL9009 System Parameters Test Circuit ($V_{IN}=18V\sim 45V$, $V_{OUT}=12V$, $I_{OUT}=0\sim 1.0A$)

Typical System Application Transfer Efficiency

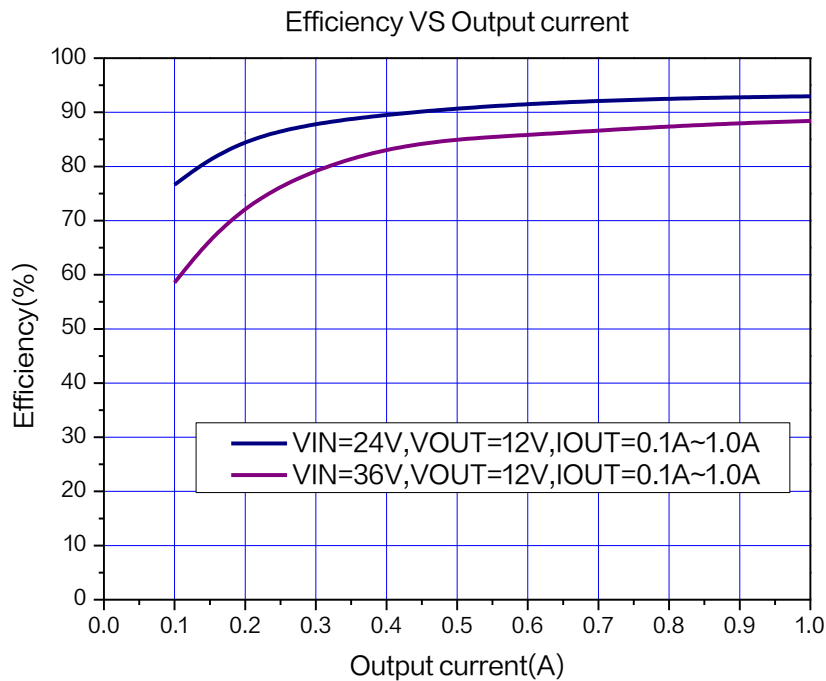
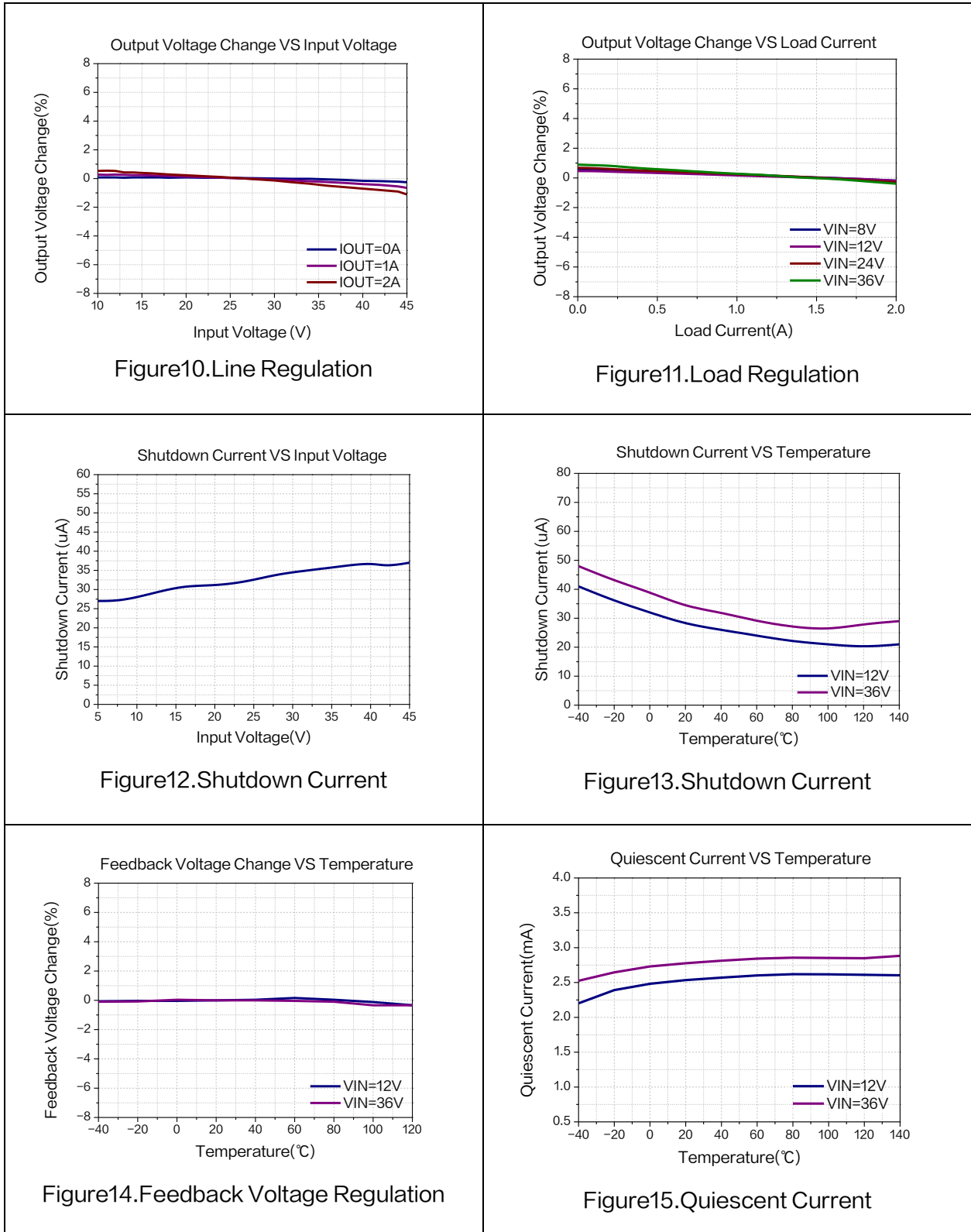

Figure9. XL9009 System Efficiency Curve ($V_{OUT}=12V$)

2.0A 200KHz 50V Synchronous Buck DC to DC Converter With CV/CC Loop XL9009

Typical Characteristics



2.0A 200KHz 50V Synchronous Buck DC to DC Converter With CV/CC Loop XL9009

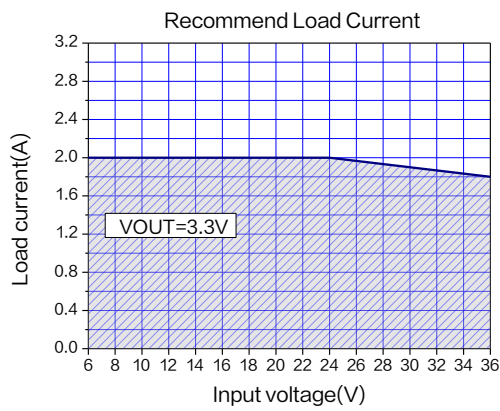

Figure 16.Max Output Current
(V_{OUT}=3.3V, T_A=25°C)

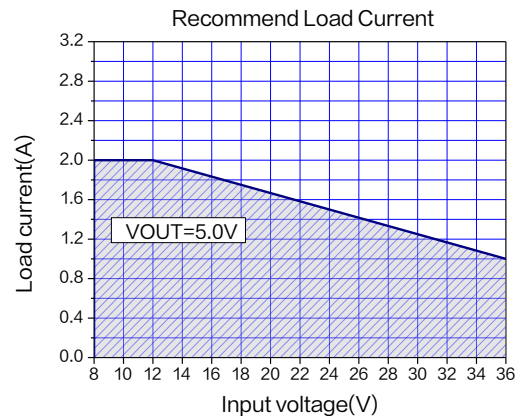

Figure 17.Max Output Current
(V_{OUT}=5.0V, T_A=25°C)

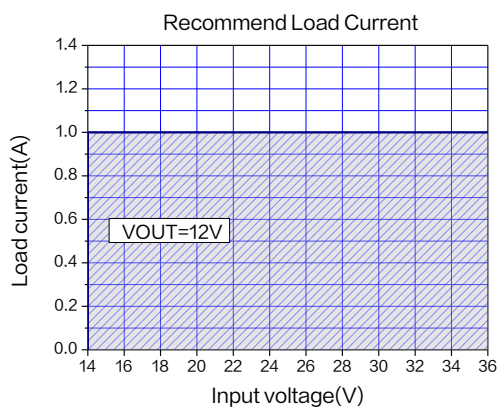

Figure 18.Max Output Current
(V_{OUT}=12V, T_A=25°C)

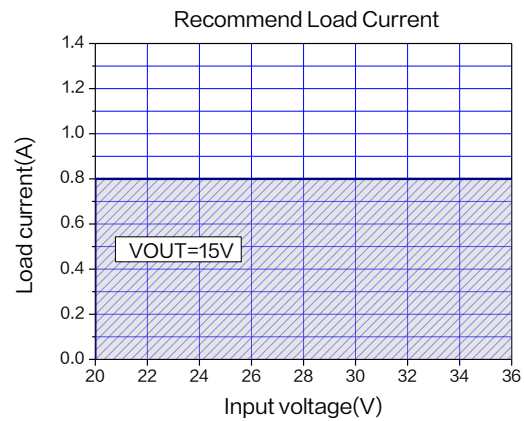

Figure 19.Max Output Current
(V_{OUT}=15V, T_A=25°C)

2.0A 200KHz 50V Synchronous Buck DC to DC Converter With CV/CC Loop XL9009

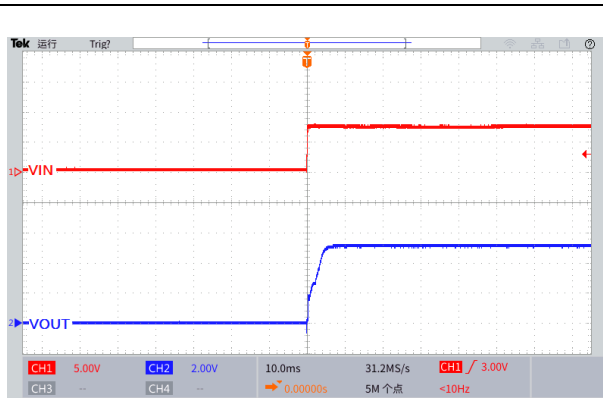

Figure 20. Start-Up Characteristic
($V_{IN}=8V$, $V_{OUT}=5.0V$, $I_{OUT}=0.1A$)

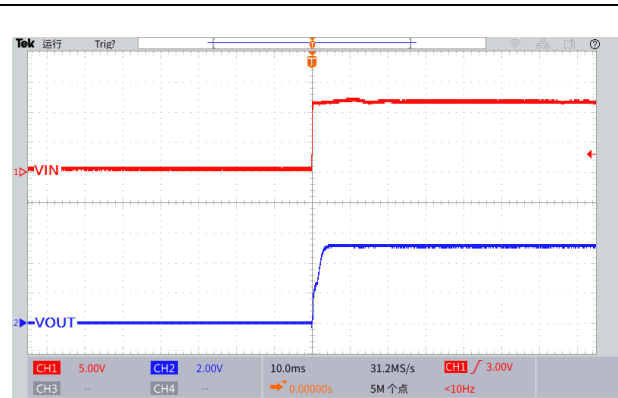

Figure 21. Start-Up Characteristic
($V_{IN}=12V$, $V_{OUT}=5.0V$, $I_{OUT}=0.1A$)

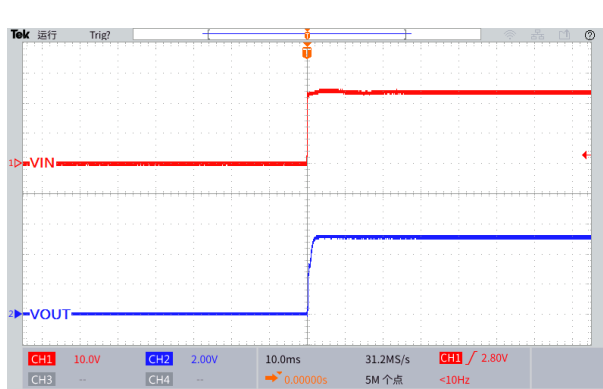

Figure 22. Start-Up Characteristic
($V_{IN}=24V$, $V_{OUT}=5.0V$, $I_{OUT}=0.1A$)

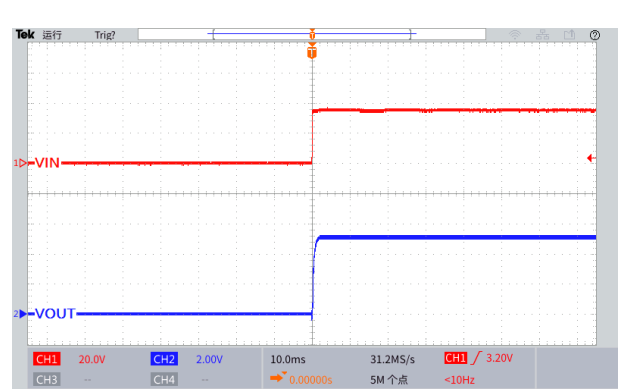

Figure 23. Start-Up Characteristic
($V_{IN}=36V$, $V_{OUT}=5.0V$, $I_{OUT}=0.1A$)

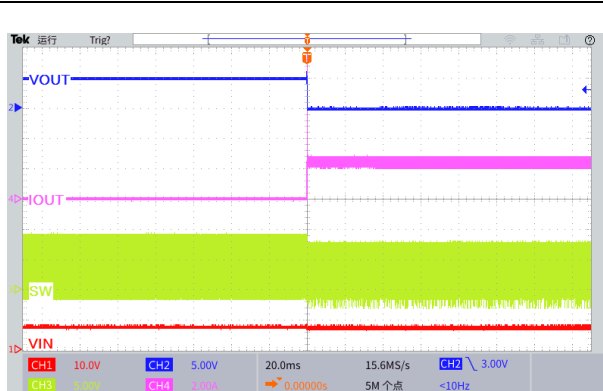

Figure 24. Output Short Circuit Waveform
($V_{IN}=8V$, $V_{OUT}=5.0V$)

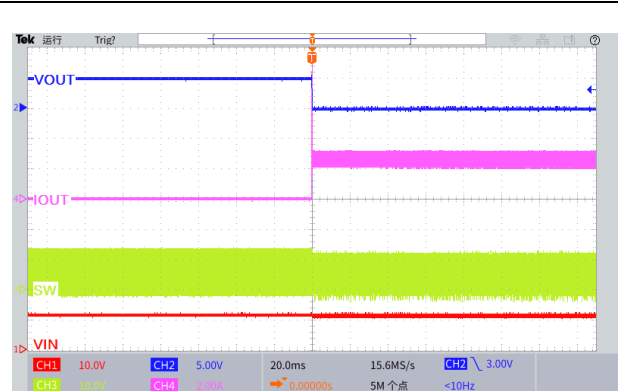

Figure 25. Output Short Circuit Waveform
($V_{IN}=12V$, $V_{OUT}=5.0V$)

2.0A 200KHz 50V Synchronous Buck DC to DC Converter With CV/CC Loop XL9009

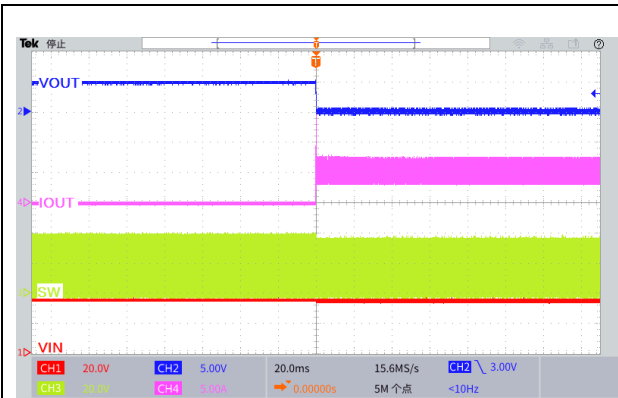

Figure 26. Output Short Circuit Waveform
($V_{IN}=24V$, $V_{OUT}=5.0V$)

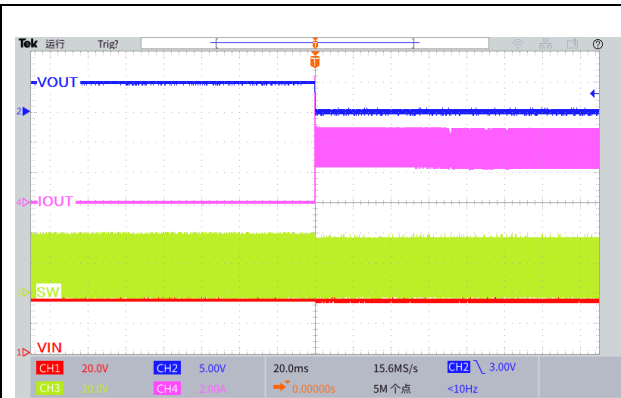

Figure 27. Output Short Circuit Waveform
($V_{IN}=36V$, $V_{OUT}=5.0V$)

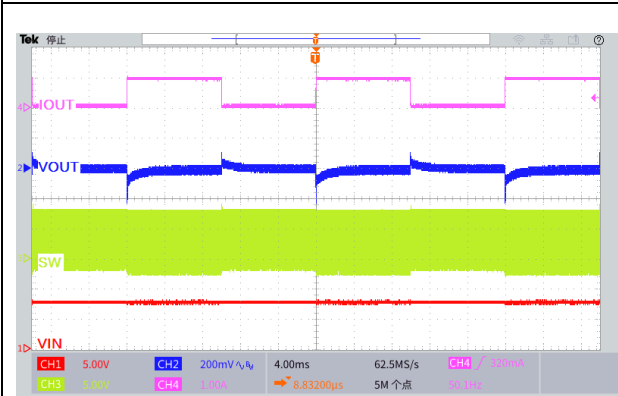

Figure28. Load Transient Response
($V_{IN}=8V$, $V_{OUT}=5.0V$, $I_{OUT}=0.1$ to 1A)

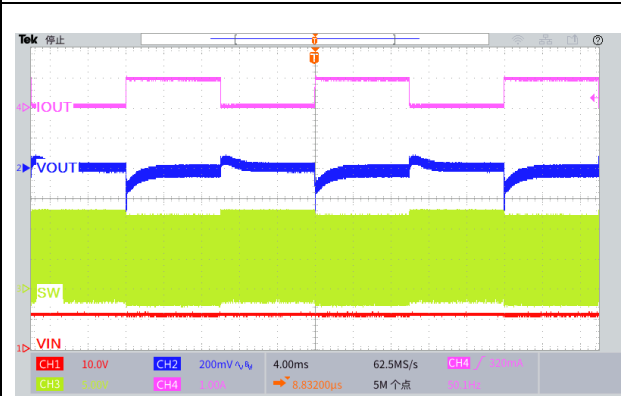

Figure29. Load Transient Response
($V_{IN}=12V$, $V_{OUT}=5.0V$, $I_{OUT}=0.1$ to 1A)

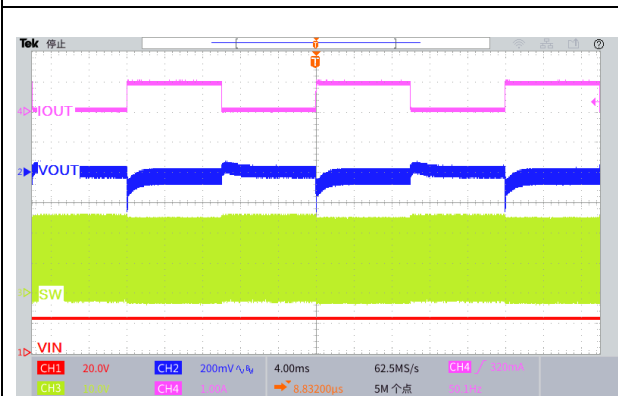

Figure30. Load Transient Response
($V_{IN}=24V$, $V_{OUT}=5.0V$, $I_{OUT}=0.1$ to 1A)

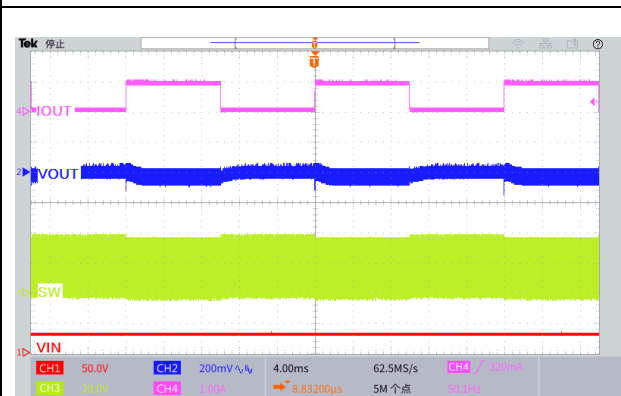

Figure31. Load Transient Response
($V_{IN}=36V$, $V_{OUT}=5.0V$, $I_{OUT}=0.1$ to 1A)

2.0A 200KHz 50V Synchronous Buck DC to DC Converter With CV/CC Loop XL9009

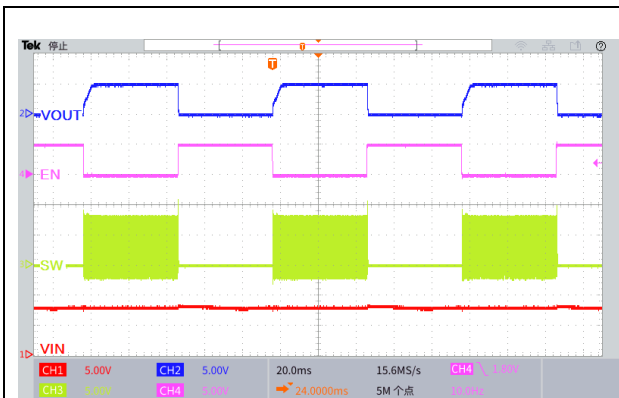

Figure32. Start or Shutdown Using EN Pin
($V_{IN}=8V$, $V_{OUT}=5.0V$, $I_{OUT}=0.5A$)

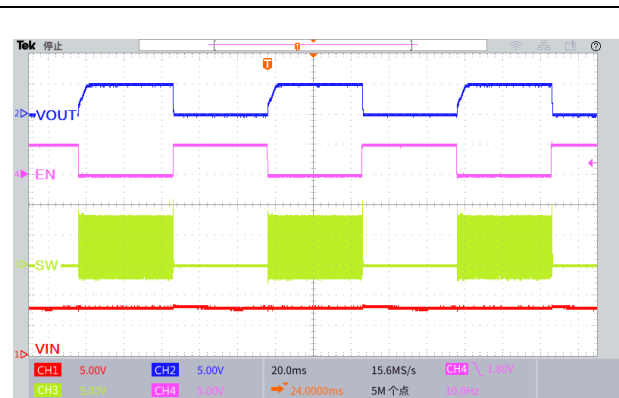

Figure33. Start or Shutdown Using EN Pin
($V_{IN}=12V$, $V_{OUT}=5.0V$, $I_{OUT}=0.5A$)

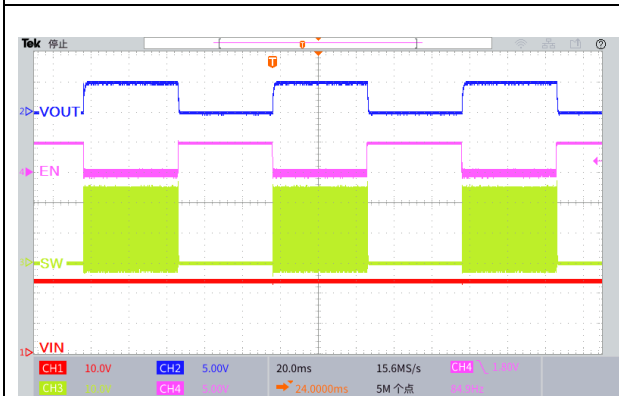

Figure34. Start or Shutdown Using EN Pin
($V_{IN}=24V$, $V_{OUT}=5.0V$, $I_{OUT}=0.5A$)

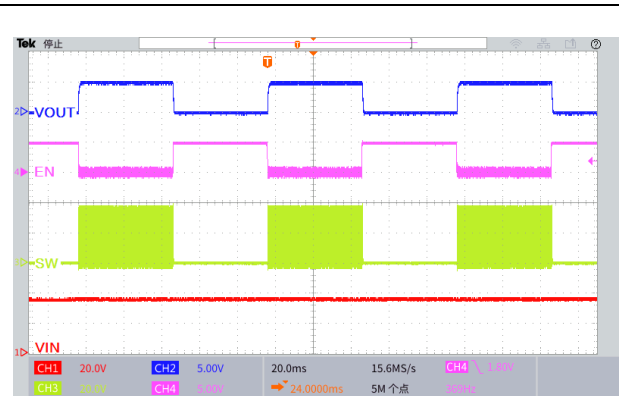
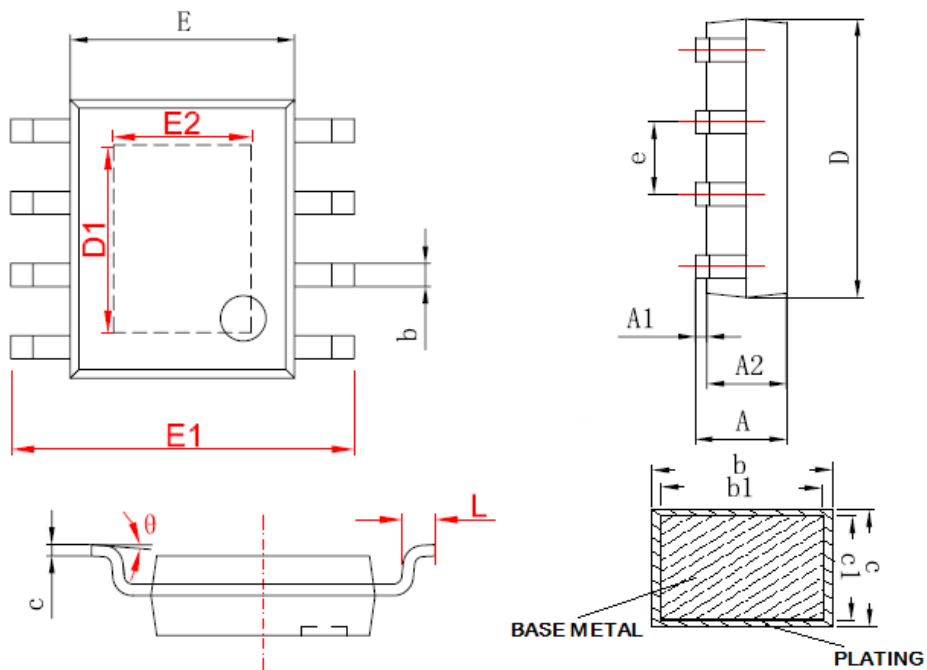

Figure35. Start or Shutdown Using EN Pin
($V_{IN}=36V$, $V_{OUT}=5.0V$, $I_{OUT}=0.5A$)

2.0A 200KHz 50V Synchronous Buck DC to DC Converter With CV/CC Loop XL9009

Package Information

SOP8-EP



Symbol	Dimensions In Millimeters		Dimensions In Inches	
	Min.	Max.	Min.	Max.
A	1.350	1.750	0.053	0.069
A1	0.000	0.150	0.000	0.006
A2	1.250	1.650	0.049	0.065
b	0.306	0.510	0.012	0.020
b1	0.296	0.480	0.011	0.019
c	0.170	0.250	0.006	0.010
c1	0.170	0.230	0.006	0.009
D	4.700	5.100	0.185	0.200
D1	2.650	3.467	0.104	0.136
E	3.800	4.000	0.150	0.157
E1	5.800	6.200	0.228	0.244
E2	1.930	2.534	0.076	0.100
e	1.140	1.400	0.045	0.055
L	0.450	0.800	0.017	0.031
θ	0°	8°	0°	8°

2.0A 200KHz 50V Synchronous Buck DC to DC Converter With CV/CC Loop XL9009

Important Notice

XLSEMI reserve the right to make modifications, enhancements, improvements, corrections or other changes without notice at any time. XLSEMI does not assume any liability arising out of the application or use of any product described herein; neither does it convey any license under its patent rights, nor the rights of others. XLSEMI assumes no liability for applications assistance or the design of Buyers' products. Buyers are responsible for their products and applications using XLSEMI components. To minimize the risks associated with Buyers' products and applications, Buyers should provide adequate design and operating safeguards. XLSEMI warrants performance of its products to the specifications applicable at the time of sale, in accordance with the warranty in XLSEMI's terms and conditions of sale of semiconductor products. Testing and other quality control techniques are used to the extent XLSEMI deems necessary to support this warranty. Except where mandated by applicable law, testing of all parameters of each component is not necessarily performed.

For the latest product information, go to www.xlsemi.com.