

Features

- Operation Voltage: 5V~45V
- 0.23V Constant Current Sense Voltage
- Directly drive 1~9 Series LED
- Current Sense Voltage Accuracy $\pm 4\%$
- Fixed 150KHz Switching Frequency
- 2A Constant Output Current Capability
- Internal Optimize Power MOSFET
- High efficiency up to 94%
- Max. Output power up to 10W
- Excellent line and load regulation
- EN PIN TTL shutdown capability
- Built in thermal shutdown function
- Built in current limit protection function
- Temperature Grade 1: -40°C to 125°C
Ambient Operating Temperature Range
- Device HBM ESD Classification Level Class3A
- Available in SOP8 package

General Description

The XL9522 is a 150KHz fixed frequency PWM synchronous buck LED constant current driver, capable of driving a 2A load with high efficiency, low ripple and excellent line and load regulation. XL9522 supports wide input operating voltage range of 5V ~ 45V and a maximum duty cycle of 90% output. A built-in loop compensation module reduces components in the system, lowering power system cost and reducing printed circuit board space.

The XL9522 has built-in thermal shutdown, current limit protection and output short protection function and so on.

Applications

- Buck constant current driver
- Monitor LED Backlighting
- General purpose LED lighting

Typical application schematic

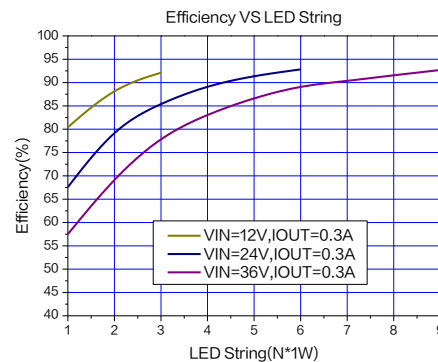
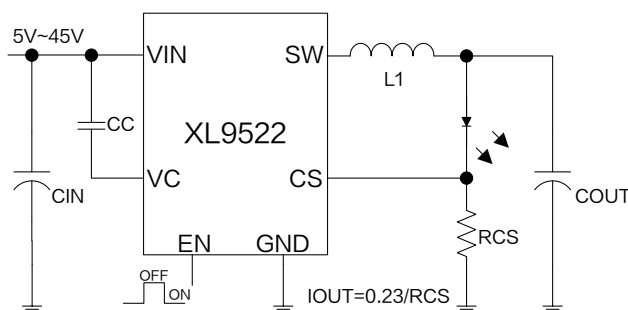

Figure1. XL9522 Typical application schematic and efficiency curve

Pin Configurations

CS	1	8	GND
EN	2	7	GND
VC	3	6	SW
VIN	4	5	SW

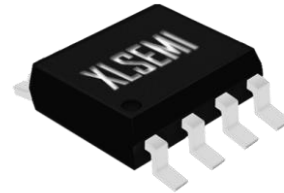

Figure2. Pin Configuration of XL9522

Table 1 Pin Description

Pin Number	Pin Name	Description
1	CS	Output constant current sense Pin (CS). The CS reference voltage is 0.23V.
2	EN	Enable Pin. Drive EN pin high to turn off the device, drive it low to turn it on. Floating is default low. Connect to GND to enable the voltage regulator.
3	VC	Internal Voltage Regulator Bypass Capacity. In typical system application, The VC pin connect a 1uF capacitor to VIN.
4	VIN	Supply Voltage Input Pin. XL9522 operates from 5V to 45V DC voltage. Bypass Vin to GND with a suitably large capacitor to eliminate noise on the input.
5,6	SW	Power Switch Output Pin (SW). Output is the switch node that supplies power to the output.
7,8	GND	Ground Pin.

Ordering Information

Order Information	Marking ID	Package Type	Eco Plan	Packing Type Supplied As
XL9522	XL9522	SOP8	RoHS & HF	4000 Units on Reel

Function Block

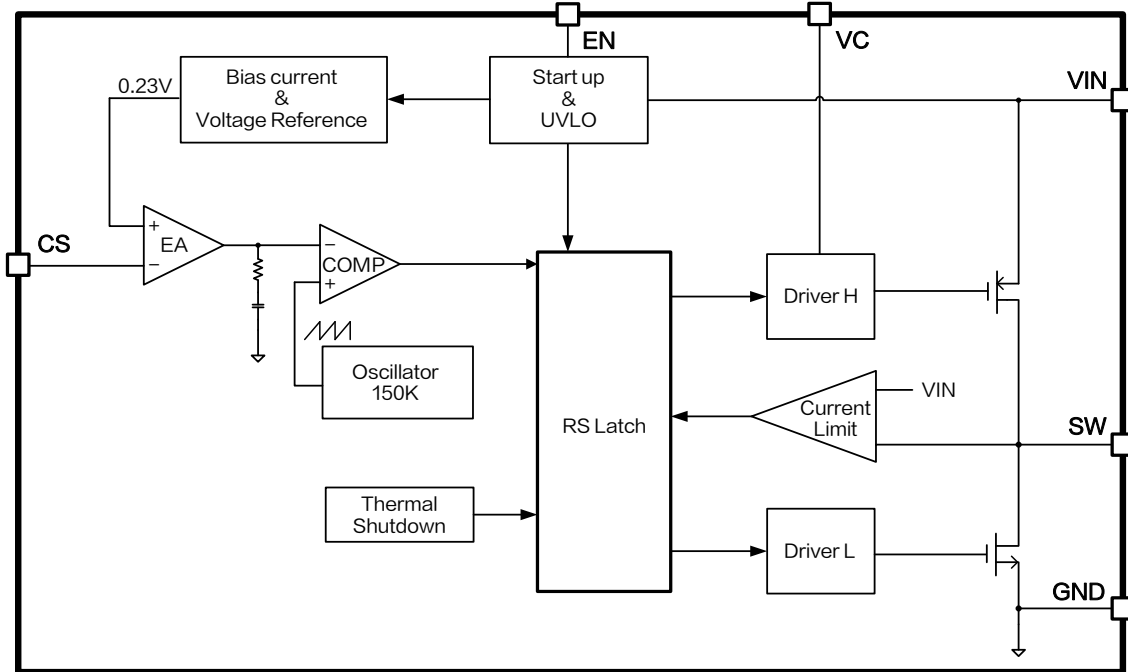

Figure3. Function Block Diagram of XL9522

Absolute Maximum Ratings (Note1)

Parameter	Symbol	Value	Unit
Input Voltage	V_{IN}	-0.3~50	V
EN Pin Voltage	V_{EN}	-0.3~7	V
Current Sense Pin Voltage	V_{CS}	-0.3~7	V
Output Switch Pin Voltage	V_{SW}	-0.3~ V_{IN}	V
VC Pin Voltage	V_C	-0.3~ V_{IN}	V
Power Dissipation	P_D	Internally limited	mW
Thermal Resistance (SOP8) (Junction to Ambient, No Heatsink, Free Air)	R_{JA}	100	°C/W
Operating Junction Temperature	T_J	-40~150	°C
Storage Temperature	T_{STG}	-65~150	°C
Lead Temperature (Soldering, 10 sec)	T_{LEAD}	260	°C
ESD (HBM)		>7000	V

Note1: Stresses greater than those listed under Maximum Ratings may cause permanent damage to the device. This is a stress rating only and functional operation of the device at these or any other conditions above those indicated in the operation is not implied. Exposure to absolute maximum rating conditions for extended periods may affect reliability.

2.0A 150KHz 50V Synchronous Buck LED Constant Current Driver

XL9522

XL9522 Electrical Characteristics

$T_A = 25^\circ\text{C}$; system parameters test circuit figure4, unless otherwise specified.

Symbol	Parameter	Test Condition	Min.	Typ.	Max.	Unit
V_{CS}	Current Sense Voltage	$V_{IN} = 12\text{V}, V_{OUT} = 3.3\text{V}$ $I_{OUT} = 0.3\text{A}$	220.8	230.0	239.2	mV
η	Efficiency	$V_{IN} = 12\text{V}, V_{OUT} = 9.9\text{V}$ $I_{OUT} = 0.3\text{A}$	-	92.1	-	%
η	Efficiency	$V_{IN} = 24\text{V}, V_{OUT} = 16.5\text{V}$ $I_{OUT} = 0.6\text{A}$	-	94.3	-	%

Electrical Characteristics (DC Parameters)

$T_A = 25^\circ\text{C}, V_{IN} = 12\text{V}, V_{EN} = 0\text{V}$; system parameters test circuit figure4, unless otherwise specified.

Parameters	Symbol	Test Condition	Min.	Typ.	Max.	Unit
Input operation voltage	V_{IN}		5		45	V
Shutdown Supply Current	I_S	$V_{EN} = 2\text{V}$		70	200	μA
Quiescent Supply Current	I_Q	$V_{CS} = 2\text{V}$		2.8	5	mA
Oscillator Frequency	F_{OSC}		127	150	172	KHz
Switch Current Limit	I_L	$V_{CS} = 0\text{V}$		2.5		A
EN Pin Threshold	V_{EN_H}	High(OFF)	1.4			V
	V_{EN_L}	Low(ON)			0.8	V
EN Shutdown Delay Time	T_{EN}			1		mS
High side MOS On-resistance	$R_{DS(ON)H}$			68		$\text{m}\Omega$
Low side MOS On-resistance	$R_{DS(ON)L}$			50		$\text{m}\Omega$
Thermal Shutdown Temperature	T_{SD}			160		$^\circ\text{C}$
Thermal Shutdown Hysteresis	T_D			20		$^\circ\text{C}$
Max. Duty Cycle	D_{MAX}			90		%

Typical System Application Schematic ($I_{OUT}=0.3A$)

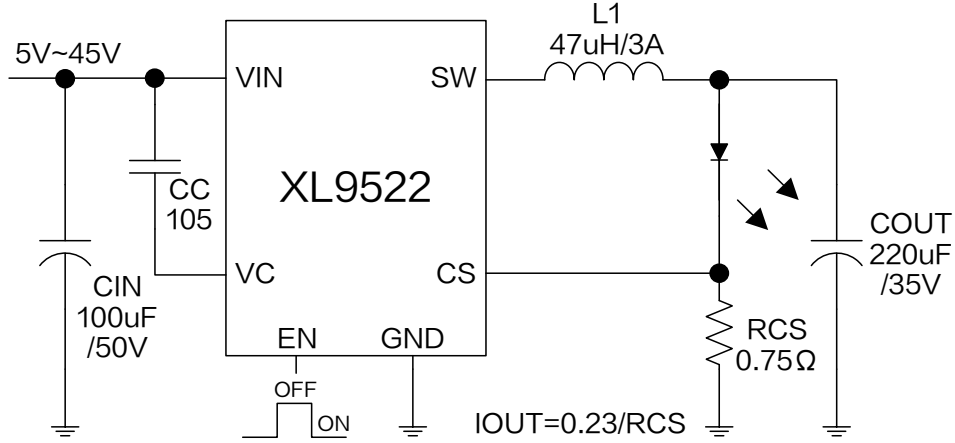

Figure4. XL9522 System Parameters Test Circuit ($I_{OUT}=0.3A$)

Typical System Application Transfer Efficiency

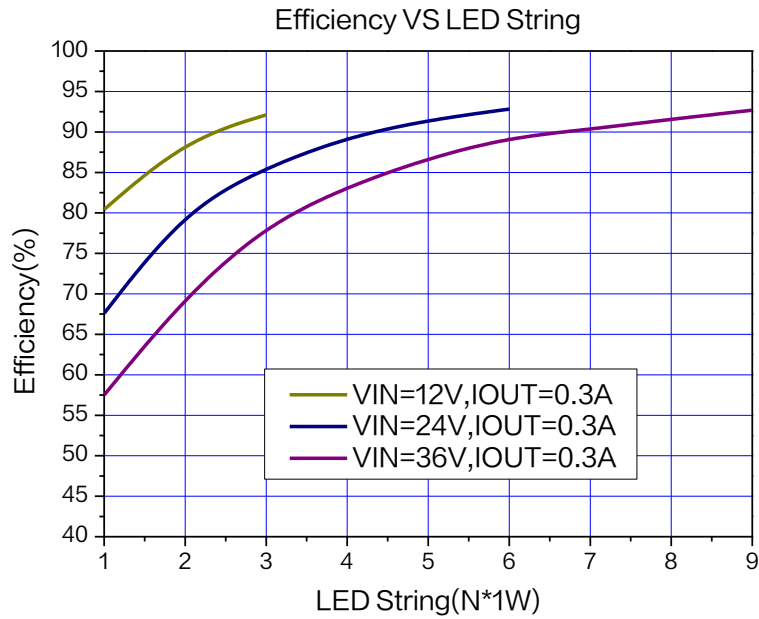

Figure5. XL9522 System Efficiency Curve ($I_{OUT}=0.3A$)

2.0A 150KHz 50V Synchronous Buck LED Constant Current Driver XL9522

Typical System Application Schematic (I_{OUT}=0.6A)

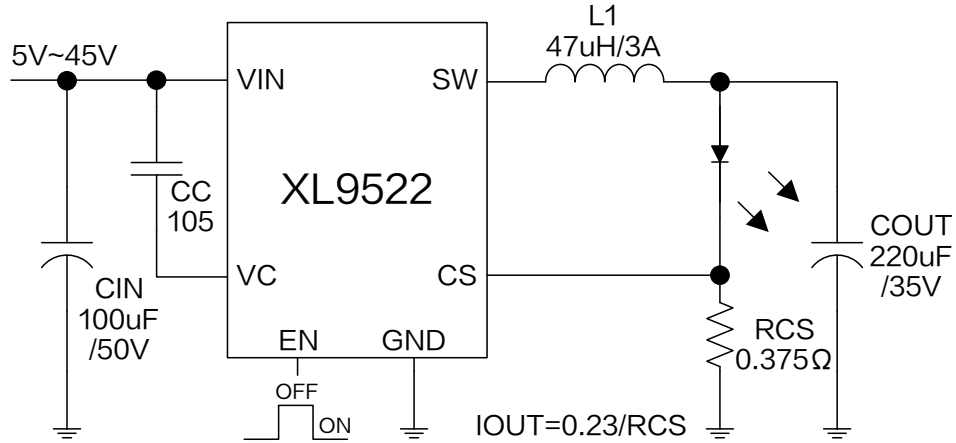

Figure6. XL9522 System Parameters Test Circuit (I_{OUT}=0.6A)

Typical System Application Transfer Efficiency

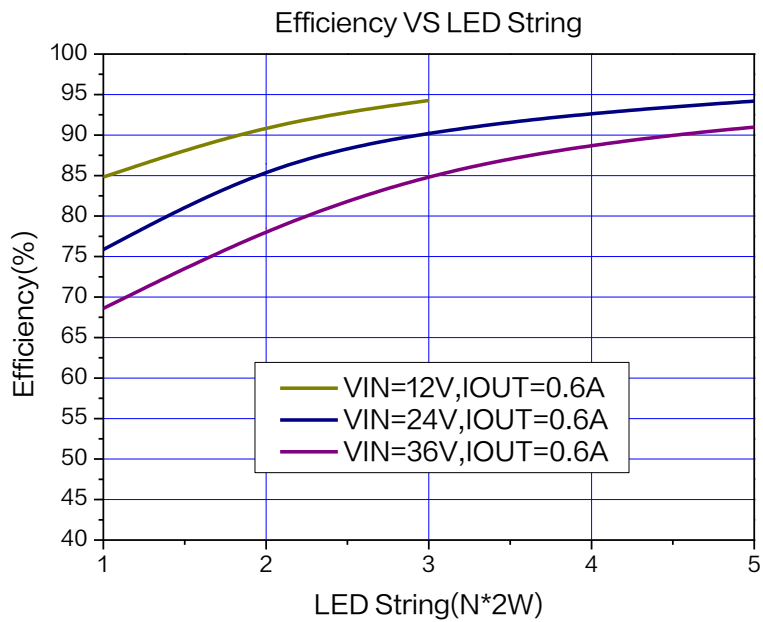

Figure7. XL9522 System Efficiency Curve (I_{OUT}=0.6A)

2.0A 150KHz 50V Synchronous Buck LED Constant Current Driver XL9522

Typical System Application Schematic ($I_{OUT}=0.9A$)

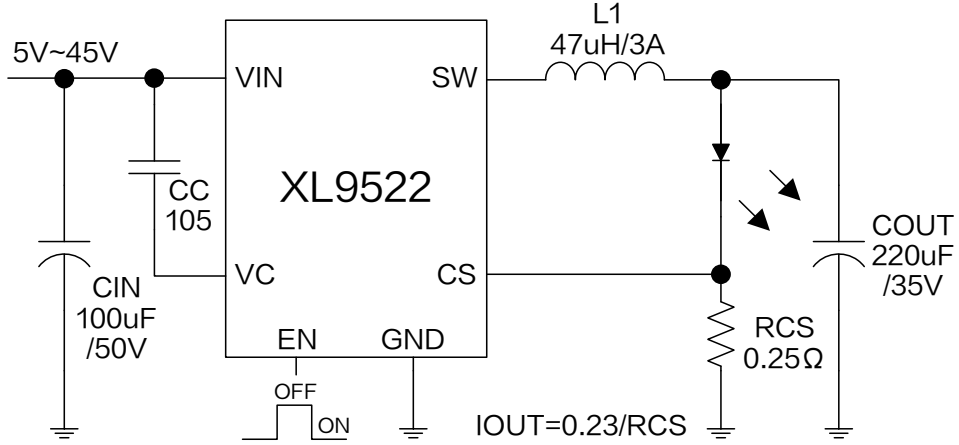

Figure8. XL9522 System Parameters Test Circuit ($I_{OUT}=0.9A$)

Typical System Application Transfer Efficiency

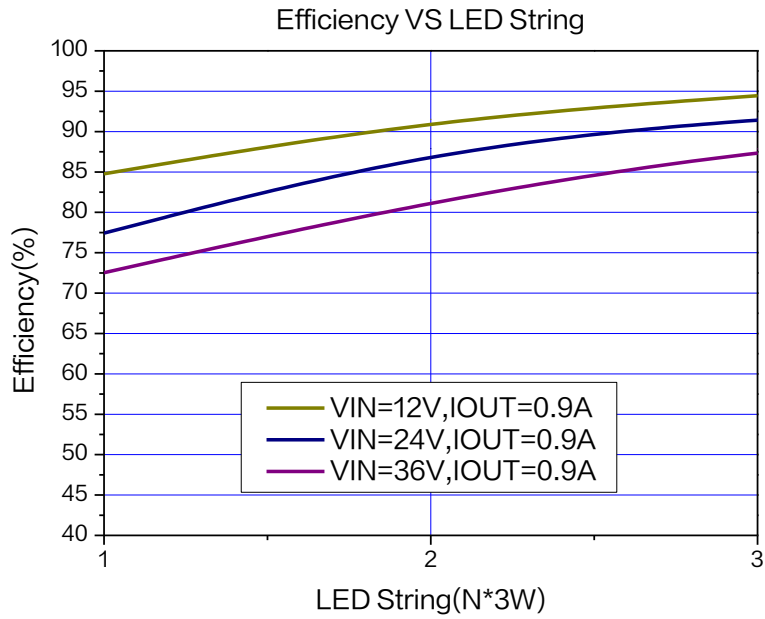

Figure9. XL9522 System Efficiency Curve ($I_{OUT}=0.9A$)

2.0A 150KHz 50V Synchronous Buck LED Constant Current Driver XL9522

Typical System Application Schematic ($I_{OUT}=1.2A$)

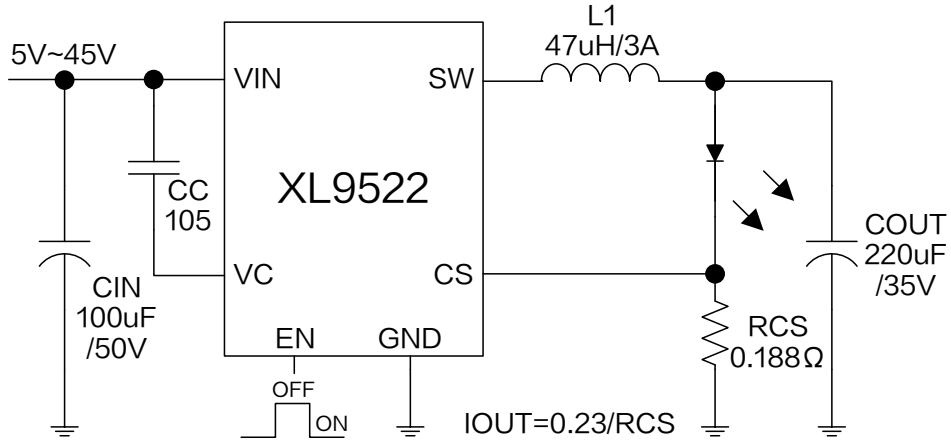

Figure10. XL9522 System Parameters Test Circuit ($I_{OUT}=1.2A$)

Typical System Application Transfer Efficiency

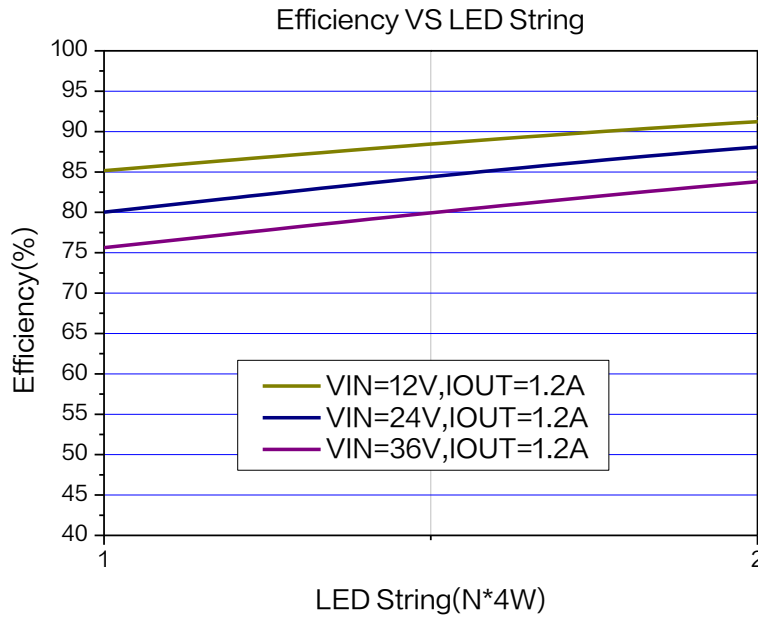

Figure11. XL9522 System Efficiency Curve ($I_{OUT}=1.2A$)

2.0A 150KHz 50V Synchronous Buck LED Constant Current Driver	XL9522
--	--------

Typical System Application (PWM DIMMING)

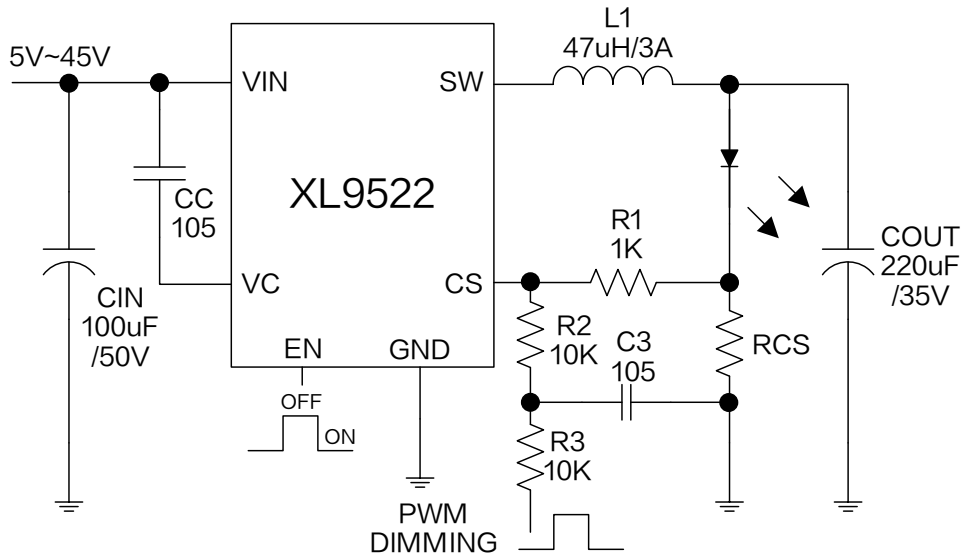

Figure12. XL9522 System Parameters Test Circuit (PWM DIMMING)

Typical Characteristics (LED forward voltage V_F is 3.3V at $I_F=0.3A$, unless otherwise noted.)

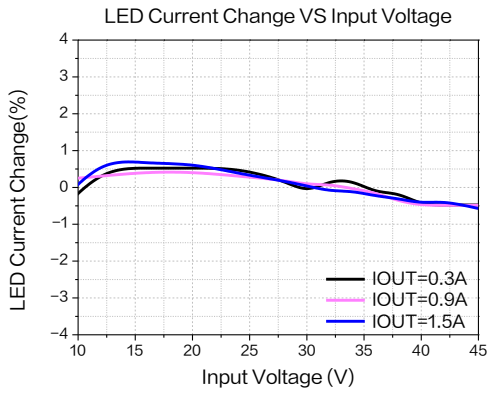

Figure13.Line Regulation

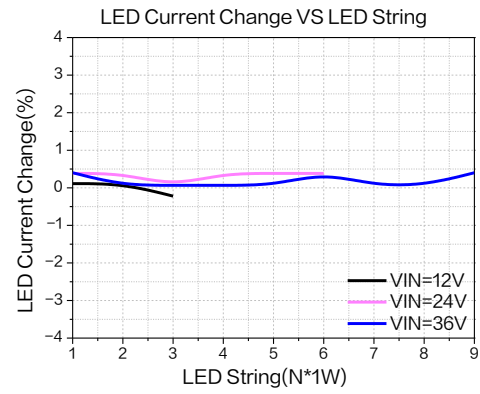

Figure14.Load Regulation

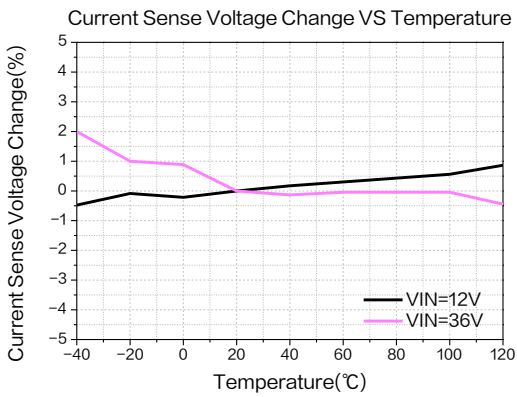

Figure15.Current Sense Voltage Regulation

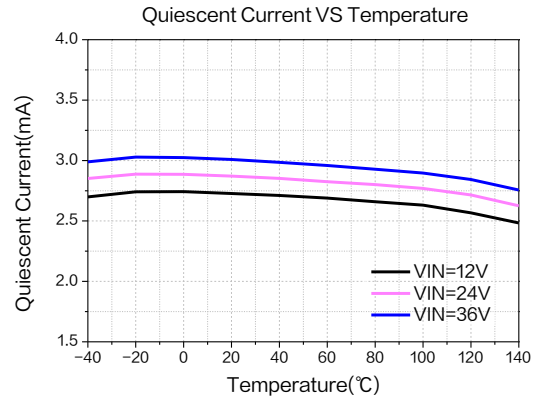

Figure16.Quiescent Current

2.0A 150KHz 50V Synchronous Buck LED Constant Current Driver

XL9522

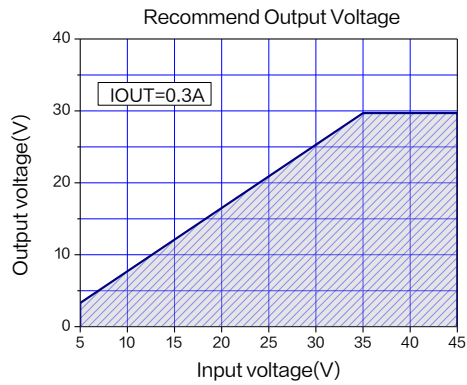

Figure17.Max Output Voltage
($I_{OUT}=0.3A$, $T_A=25^\circ C$)

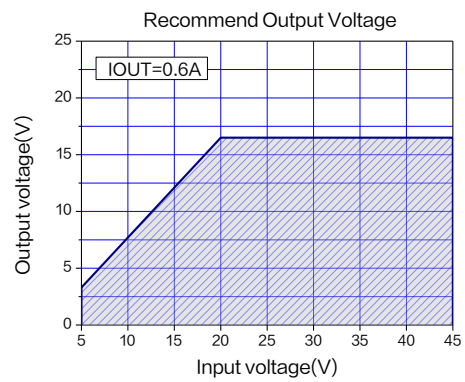

Figure18.Max Output Voltage
($I_{OUT}=0.6A$, $T_A=25^\circ C$)

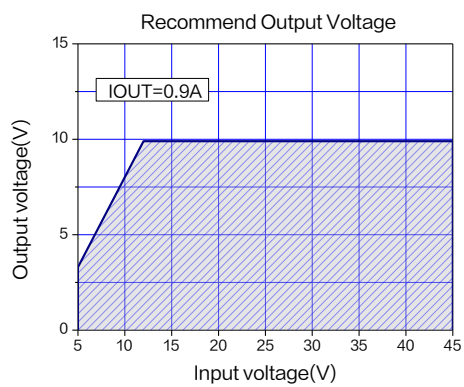

Figure19.Max Output Voltage
($I_{OUT}=0.9A$, $T_A=25^\circ C$)

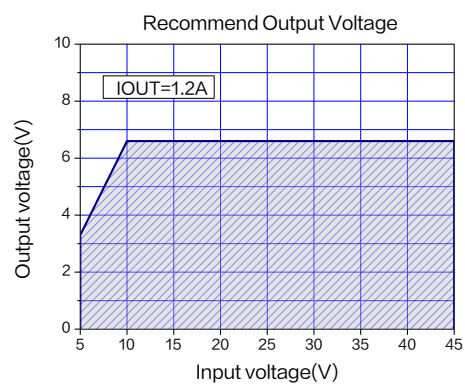

Figure20.Max Output Voltage
($I_{OUT}=1.2A$, $T_A=25^\circ C$)

2.0A 150KHz 50V Synchronous Buck LED Constant Current Driver

XL9522

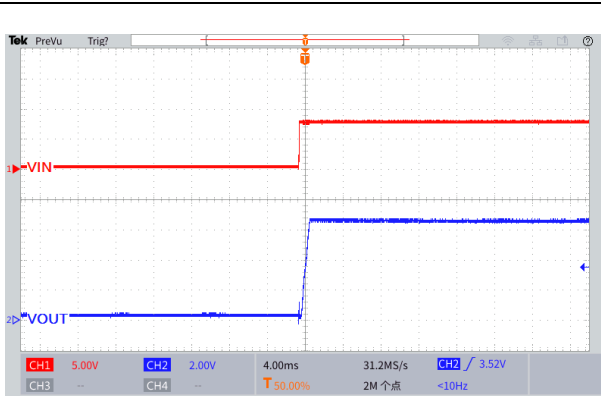

Figure21. Start-Up Characteristic
($V_{IN}=8V$, $V_{OUT}=6.6V$, $I_{OUT}=0.3A$)

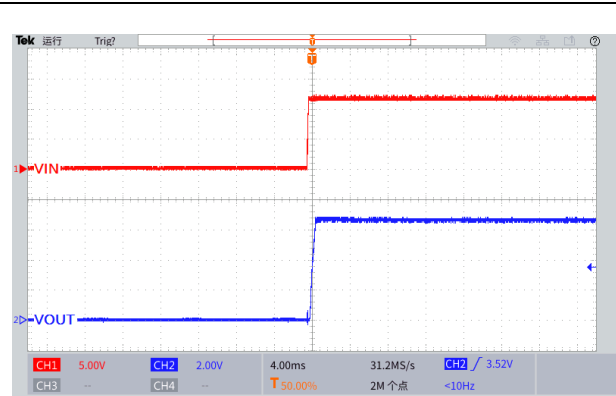

Figure22. Start-Up Characteristic
($V_{IN}=12V$, $V_{OUT}=6.6V$, $I_{OUT}=0.3A$)

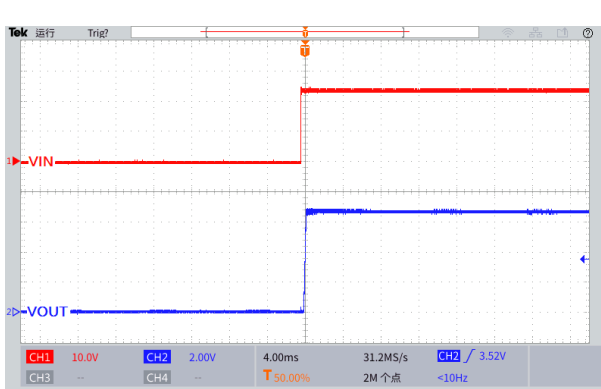

Figure23. Start-Up Characteristic
($V_{IN}=24V$, $V_{OUT}=6.6V$, $I_{OUT}=0.3A$)

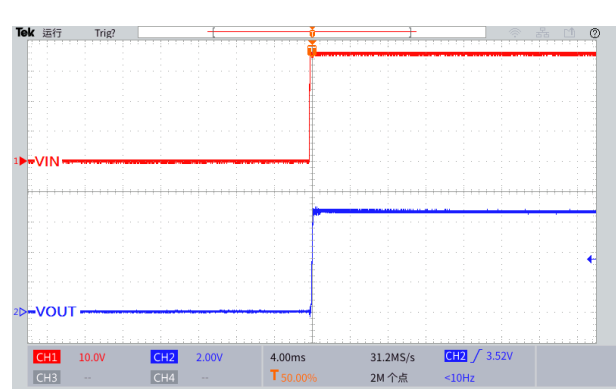

Figure24. Start-Up Characteristic
($V_{IN}=36V$, $V_{OUT}=6.6V$, $I_{OUT}=0.3A$)

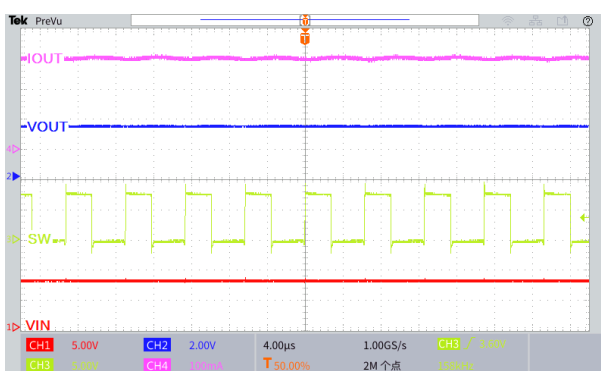

Figure25. LED Current Ripple
($V_{IN}=8V$, $V_{OUT}=3.3V$, $I_{OUT}=0.3A$)

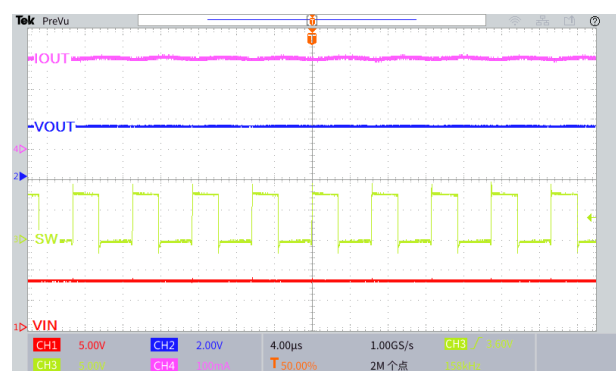

Figure26. LED Current Ripple
($V_{IN}=12V$, $V_{OUT}=6.6V$, $I_{OUT}=0.3A$)

2.0A 150KHz 50V Synchronous Buck LED Constant Current Driver

XL9522

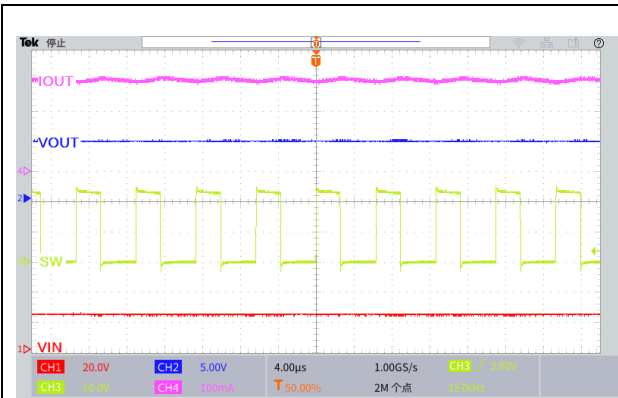

Figure27. LED Current Ripple
($V_{IN}=24V$, $V_{OUT}=9.9V$, $I_{OUT}=0.3A$)

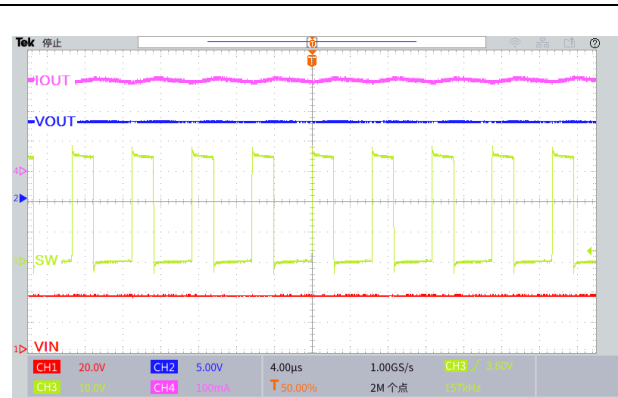

Figure28. LED Current Ripple
($V_{IN}=36V$, $V_{OUT}=13.2V$, $I_{OUT}=0.3A$)

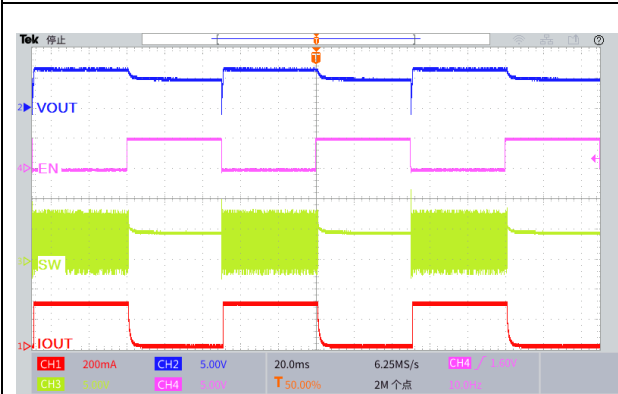

Figure29. Start or Shutdown Using EN Pin
($V_{IN}=8V$, $V_{OUT}=6.6V$, $I_{OUT}=0.3A$)

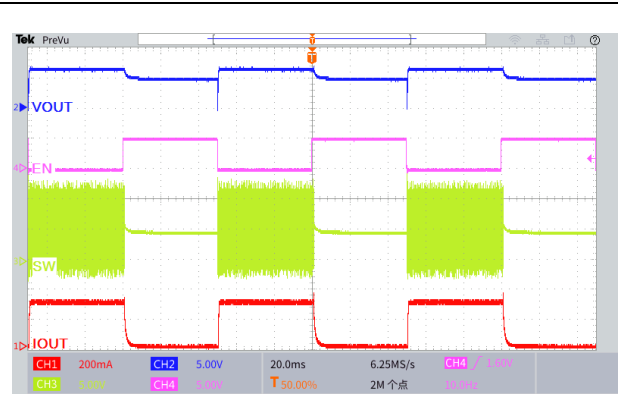

Figure30. Start or Shutdown Using EN Pin
($V_{IN}=12V$, $V_{OUT}=6.6V$, $I_{OUT}=0.3A$)

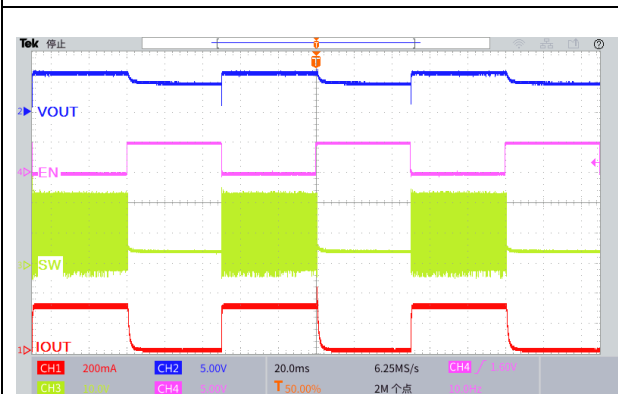

Figure31. Start or Shutdown Using EN Pin
($V_{IN}=24V$, $V_{OUT}=6.6V$, $I_{OUT}=0.3A$)

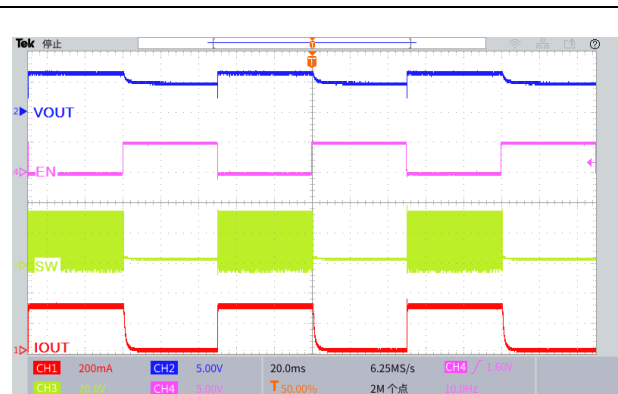
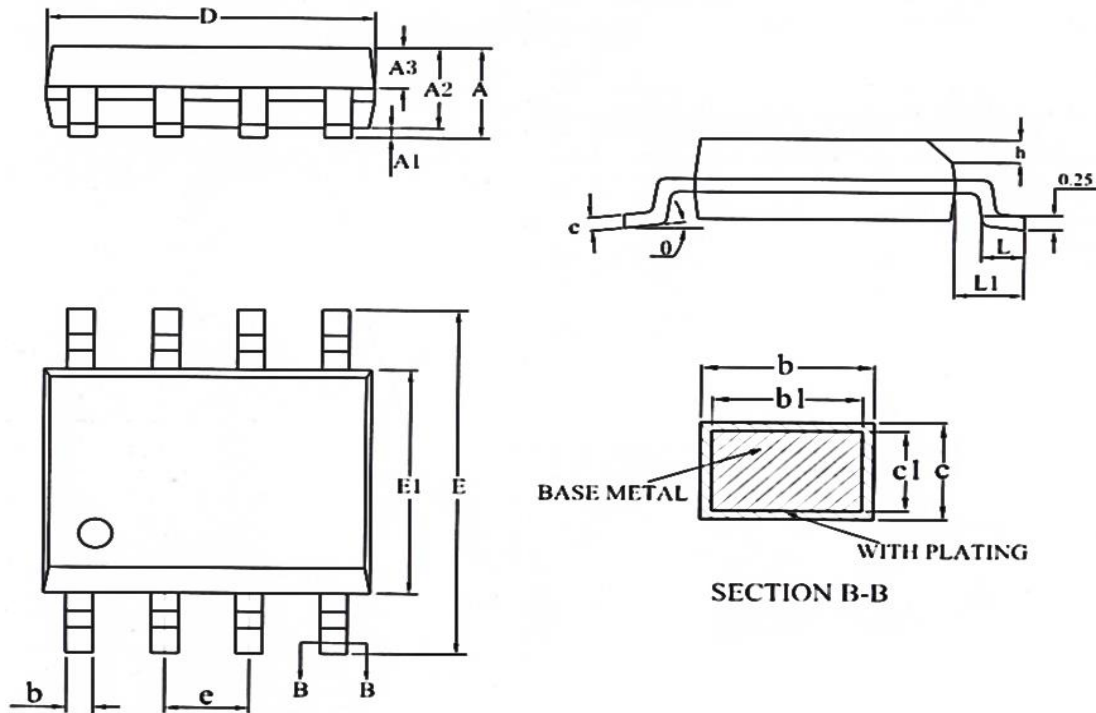

Figure32. Start or Shutdown Using EN Pin
($V_{IN}=36V$, $V_{OUT}=6.6V$, $I_{OUT}=0.3A$)

Package Information

SOP8



Symbol	Dimensions In Millimeters			Dimensions In Inches		
	Min.	Nom.	Max.	Min.	Nom.	Max.
A	1.35	1.55	1.75	0.053	0.061	0.069
A1	0.05	-	0.25	0.002	-	0.010
A2	1.25	1.40	1.65	0.049	0.055	0.065
A3	0.50	0.60	0.70	0.019	0.024	0.028
b	0.30	-	0.51	0.012	-	0.020
b1	0.29	0.41	0.48	0.011	0.016	0.018
c	0.17	-	0.25	0.007	-	0.010
c1	0.17	0.20	0.23	0.007	0.008	0.009
D	4.70	4.90	5.10	0.185	0.193	0.200
E	5.80	6.00	6.20	0.228	0.236	0.244
E1	3.80	3.90	4.00	0.150	0.154	0.157
e	1.14	1.27	1.40	0.045	0.050	0.055
h	0.25	-	0.50	0.010	-	0.020
L	0.45	-	0.80	0.017	-	0.031
L1	0.82	1.03	1.23	0.032	0.040	0.048
θ	0	-	8°	0	-	8°

2.0A 150KHz 50V Synchronous Buck LED Constant Current Driver**XL9522**

Important Notice

XLSEMI reserve the right to make modifications, enhancements, improvements, corrections or other changes without notice at any time. XLSEMI does not assume any liability arising out of the application or use of any product described herein; neither does it convey any license under its patent rights, nor the rights of others. XLSEMI assumes no liability for applications assistance or the design of Buyers' products. Buyers are responsible for their products and applications using XLSEMI components. To minimize the risks associated with Buyers' products and applications, Buyers should provide adequate design and operating safeguards. XLSEMI warrants performance of its products to the specifications applicable at the time of sale, in accordance with the warranty in XLSEMI's terms and conditions of sale of semiconductor products. Testing and other quality control techniques are used to the extent XLSEMI deems necessary to support this warranty. Except where mandated by applicable law, testing of all parameters of each component is not necessarily performed.

For the latest product information, go to www.xlsemi.com.